

Copies of this document may be purchased from:
Global Engineering, 15 Inverness Way East,
Englewood, CO 80112-5704
Phone: (800) 854-7179 or (303) 792-2181 Fax: (303) 792-2192

dpANS X3.xxx-199x
X3T11/Project 1119D/Rev 9.1

FIBRE CHANNEL

PHYSICAL AND SIGNALLING INTERFACE - 3 (FC-PH-3)

REV 9.1

working draft proposed
American National Standard
for Information Systems

October 15, 1996

Secretariat:
Information Technology Industry Council

ABSTRACT: This standard describes the enhancement to the ANSI X3.230, Fibre Channel Physical and Signalling Interface (FC-PH) and to the ANSI X3.297, Fibre Channel Physical and Signalling Interface - 2 (FC-PH-2) and is an addendum to both these documents.

NOTE:

This is a draft proposed American National Standard of Accredited Standards Committee X3. As such, this is not a completed standard. The X3T11 Technical Committee may modify this document as a result of comments received during public review and its approval as a standard.

POINTS OF CONTACT:

Roger Cummings (X3T11 Chairman)
Distributed Processing Technology
140 Candace Drive
Maitland, FL 32751
(407) 830-5522 x348 Fax: (407) 260-5366
E-Mail: cummings_roger@dpt.com

I. Dal Allan
(Fibre Channel Working Group Chairman)
ENDL
14426 Black Walnut Court
Saratoga, CA 95070
(408) 867-6630 Fax: (408) 867-2115
E-Mail: dal_allan@mcimail.com

Carl Zeitler (X3T11 Vice Chairman)
IBM Corporation - AWD, MS 9440
11400 Burnet Road, Austin, TX 78758
(512) 838-1797 Fax: (512) 838-1852
E-Mail: zeitler@ausvm6.vnet.ibm.com

Bryan Cook (Editor)
IBM Corporation, MS P323
522 South Road, Poughkeepsie, NY 12601
(914) 435-7914 Fax: (914) 432-9417
E-Mail: bryan_cook@vnet.ibm.com

Changed from Revision 9.0:

- Revised Clauses 7, 9, and Annex F as a result of the X3T11 Letter Ballot.
- Changed BER definition in 5.1 to reflect FC-PH-2.

draft proposed American National Standard
for Information Technology —
Fibre Channel — Physical and Signalling Interface - 3
(FC-PH-3)

Secretariat
Information Technology Industry Council

Approved _____, 199
American National Standards Institute, Inc.

Abstract

This standard describes the enhancement to the ANSI X3.230, Fibre Channel Physical and Signalling Interface (FC-PH) and to the ANSI X3.297, Fibre Channel Physical and Signalling Interface - 2 (FC-PH-2) and is an addendum to both these documents.

American National Standard

Approval of an American National Standard requires verification by ANSI that the requirements for due process, consensus, and other criteria for approval have been met by the standards developer.

Consensus is established when, in the judgement of the ANSI Board of Standards Review, substantial agreement has been reached by directly and materially affected interests. Substantial agreement means much more than a simple majority, but not necessarily unanimity. Consensus requires that all views and objections be considered, and that a concerted effort be made towards their resolution.

The use of American National Standards is completely voluntary; their existence does not in any respect preclude anyone, whether he has approved the standards or not, from manufacturing, marketing, purchasing, or using products, processes, or procedures not conforming to the standards.

The American National Standards Institute does not develop standards and will in no circumstances give interpretation on any American National Standard. Moreover, no person shall have the right or authority to issue an interpretation of an American National Standard in the name of the American National Standards Institute. Requests for interpretations should be addressed to the secretariat or sponsor whose name appears on the title page of this standard.

CAUTION NOTICE: This American National Standard may be revised or withdrawn at any time. The procedures of the American National Standards Institute require that action be taken periodically to reaffirm, revise, or withdraw this standard. Purchasers of American National Standards may receive current information on all standards by calling or writing the American National Standards Institute.

Published by

**American National Standards Institute
11 W. 42nd Street, New York, New York 10036**

Copyright © 199x by American National Standards Institute
All rights reserved

No part of this publication may be reproduced in any form, in an electronic retrieval system or otherwise, without prior written permission of the publisher.

Printed in the United States of America

INSERT CODE HERE

Contents

	Page
Foreword	xviii
Introduction	xix
1 Scope	1
2 Normative References	1
2.1 Approved references	1
2.2 References under development	1
3 Definitions and conventions	2
3.1 Definitions	2
3.1.1 FC-4 Region	2
3.1.2 Profile	2
3.2 Editorial conventions	2
3.3 Abbreviations, acronyms and symbols	2
3.3.1 Acronyms and other abbreviations	2
4 Structure and concepts	3
4.16 FC-4 Regions	3
5 FC-0 functional characteristics	5
5.1 General Characteristics	5
6 Optical fibre interface specification	5
7 Electrical cable interface specification	6
7.1 Electrical data links	7
7.2 Reference locations	9
7.2.1 Intercabinet references	9
7.2.2 Intracabinet references	9
7.3 75 W unbalanced data links	9
7.3.1 ECL compatible driver characteristics	9
7.3.2 ECL compatible receiver characteristics	9
7.3.3 Unbalanced cable characteristics	10
7.3.4 Unbalanced cable connectors	11
7.3.4.1 Intercabinet connectors for unbalanced cable	11
7.3.4.2 Style-1 unbalanced cable connector	11
7.3.4.3 Style-2 unbalanced cable connector	11
7.3.4.4 Intracabinet connectors for unbalanced cable	11
7.4 150W balanced data links	11
7.4.1 ECL compatible driver characteristics	11

	Page
7.4.2 ECL compatible receiver characteristics	12
7.4.3 Balanced cable characteristics	12
7.4.4 Balanced cable connectors	13
7.4.4.1 Intercabinet connectors for balanced cable	13
7.4.4.2 Style-1 balanced cable connector	13
7.4.4.3 Style-2 balanced cable connector	13
7.4.4.3.1 Style-2 plug	14
7.4.4.3.2 Style-2 receptacle	14
7.4.4.4 Optional intercabinet connector pins	14
7.4.4.5 Intracabinet connectors for balanced cable	15
7.4.4.6 Intracabinet connectors for balanced cable	15
8 Optical fibre cable plant specification	16
9 Electrical cable plant specification	17
9.1 Unbalanced cable plant	17
9.1.1 LV (long-video) cable plant specification	17
9.1.1.1 LV-type	17
9.1.1.2 Shielding	17
9.1.2 TV (video) cable plant specification	17
9.1.2.1 TV-type	18
9.1.2.2 Shielding	18
9.1.3 MI (miniature) cable plant specification	18
9.1.3.1 MI-type	18
9.1.3.2 Shielding	18
9.1.4 Unbalanced cable interoperability	18
9.2 Balanced cable plant	18
9.2.1 TP (shielded twisted pair) cable plant specification	18
9.2.1.1 TP-type	18
9.2.1.2 Shielding	19
9.2.2 TW cable plant specification	19
9.2.2.1 TW-type	19
9.2.2.2 Shielding	19
9.2.3 Balanced cable interoperability	20
10 Optical interface connector specification	21
11 FC-1 8B/10B Transmission Code	21

	Page
12 FC-1 receiver and transmitter description	21
13 Loopback mode	21
14 Diagnostic mode	21
15 Transmitter safety	21
16 Ordered sets	21
17 Frame formats	21
18 Frame_Header	22
18.3 Address identifiers	22
18.4 Data Structure (TYPE)	22
18.5 Frame Control (F_CTL)	22
18.6 Sequence_ID (SEQ_ID)	26
18.7 DF_CTL	26
18.9 Word 4, Bits 31-16	26
18.9.1 Originator Exchange_ID (OX_ID)	26
18.9.2 Priority	27
19 Optional headers	28
19.1 Introduction	28
19.2 Expiration_Security_Header	28
19.3 Network_Header	28
19.3.1 D_NAA or S_NAA	28
19.3.2.5 CCITT 60-bit address	29
19.4 Association Header	29
20 Data frames and responses	30
20.3 Link_Control	30
20.3.3.2 N_Port Busy (P_BSY)	30
20.3.3.3 Reject (P_RJT, F_RJT)	30
21 Link Services	31
21.1.1 Default Login values	31
21.2 Basic Link Service commands	31
21.2.7 Dedicated Connection Preempted (PRMT)	32
21.3 Extended Link Services	32
21.4 Extended Link Service requests	34
21.4.13 Read Timeout Value (RTV)	34
21.5 Extended Link Service reply Sequences	34

	Page
21.5.2 Link Service Reject (LS_RJT)	34
21.20 Report Node Capabilities Information (RNC)	35
22 Classes of Service	40
22.6 Class 6 - Uni-Directional Dedicated Connection	40
22.6.1 Class 6 function	40
22.6.2 Class 6 rules	40
22.6.3 Class 6 delimiters	41
22.6.4 Class 6 frame size	41
22.6.5 Class 6 flow control	41
22.6.6 Stacked Connect-requests	42
23 Login and Service Parameters	43
23.1 Introduction	43
23.2 Applicability	43
23.3 Fabric Login	43
23.3.1 Explicit Fabric Login	43
23.3.2 Responses to Fabric Login	44
23.3.2.1 FLOGI with S_ID = 0 or 0000yy	44
23.6 N_Port Service Parameters	45
23.6.1 N_Port Common Service Parameters	46
23.6.2 N_Port Common Service parameters - Fabric Login	48
23.6.2.1 FC-PH-3 version	48
23.6.2.2 Buffer-to-buffer credit	48
23.6.2.3 Common features	48
23.6.2.4 Buffer-to-buffer Data_Field size	48
23.6.3 N_Port Common Service Parameters - N_Port Login	48
23.6.3.1 FC-PH-3 version	49
23.6.3.2 Buffer-to-buffer credit	49
23.6.3.3 Common features	49
23.6.3.4 Buffer-to-buffer Data_Field size	49
23.6.3.5 Total Concurrent Sequences	49
23.6.3.6 Relative Offset by category	49
23.6.3.7 Point-to-point E_D_TOV value	49
23.6.6 N_Port Class Service Parameters	50
23.6.7 N_Port Class Service Parameters - Fabric Login	52

	Page
23.6.7.1 Class Validity (V)	52
23.6.7.2 Service Options	52
23.6.7.3 Initiator control	52
23.6.7.4 Recipient control	52
23.6.7.5 Receive Data_Field Size	52
23.6.7.6 Concurrent Sequences	52
23.6.7.7 N_Port End-to-end Credit	52
23.6.7.8 Open Sequences per Exchange	52
23.6.8 N_Port Class Service Parameters - N_Port Login	52
23.6.8.1 Class Validity (V)	52
23.6.8.2 Service Options	52
23.6.8.3 Initiator control	53
23.6.8.4 Recipient control	53
23.6.8.5 Receive Data_Field Size	53
23.6.8.6 Concurrent Sequences	53
23.6.8.7 N_Port End-to-end Credit	54
23.6.8.8 Open Sequences per Exchange	54
23.6.8.9 Class 6 Multicast RX_ID	54
23.6.9 Vendor Version Level	54
23.6.10 Services Availability	54
23.7 F_Port Service Parameters	54
23.7.1 F_Port Common Service Parameters	54
23.7.1.1 FC-PH-3 version	54
23.7.1.2 Buffer-to-buffer (F_Port) Credit	54
23.7.1.3 Common features	54
23.7.1.4 Buffer-to-buffer Data_Field size	55
23.7.1.5 E_D_TOV	55
23.7.1.6 R_A_TOV	55
23.7.2 F_Port Name	55
23.7.3 Fabric Name	55
23.7.4 F_Port Class service Parameters	55
23.7.4.1 Class Validity	55
23.7.4.2 Service Options	55
23.7.4.3 Initiator control	55

	Page
23.7.4.4 Recipient control	55
23.7.4.5 Receive Data_Field Size	56
23.7.4.6 Concurrent Sequences	56
23.7.4.7 N_Port End-to-end Credit	56
23.7.4.8 Open Sequences per Exchange	56
23.7.4.9 C_R_TOV	56
23.7.5 Vendor Version Level	56
23.7.6 Services Availability	56
23.8 Procedure to estimate end-to-end Credit	57
24 Exchange, Sequence, and sequence count management	58
24.3 Summary rules	58
24.3.1 Exchange management	58
24.3.7 Normal ACK processing	58
24.3.11 Sequence errors - Class 3	58
24.3.11.1 Rules common to all Discard policies	58
24.3.11.2 Process with infinite buffers Error Policy	58
24.8 Status blocks	58
24.8.1 Exchange Status Block	58
24.8.2 Sequence Status Block	59
25 Association Header management and usage	60
26 Flow control management	60
27 Segmentation and reassembly	60
28 Connection management	61
28.1 Introduction	61
28.4 Connect/disconnect rules	61
28.4.1 Connect-request rules	61
28.4.1.1 Source of connect-request	61
28.5 Establishing a Connection	61
28.5.4 Destination of a connect-request	61
28.9 Connection Preemption	61
28.9.1 Applicability	61
28.9.2 Topology Model	61
28.9.3 Rules for Preemption	61
28.9.3.1 Preemptor (P)	62

	Page
28.9.3.2 Preempted Source (PS)	62
28.9.3.3 Preempted Destination(s)(PD)	63
28.9.3.4 Preemption Destination(s) (PnD)	63
28.9.4 Connection Rules	63
28.9.5 Remove Connection Rules	63
28.10 Establishing a Connection Using Preemption	63
28.10.1 Connection Initiator	63
28.10.2 Preemption Destination	65
29 Error detection and recovery	66
29.2.1.2 E_D_TOV	66
29.6 Exchange integrity	66
30 Hunt Group	67
31 Multicast	68
31.1 Introduction	68
31.2 Class 6 Multicast	68
31.2.1 Class 6 Multicast Routing	68
31.2.2 Class 6 Multicast Rules	68
31.2.3 Class 6 Multicast Server	69
31.2.4 Class 6 Multicast recovery	69
31.3 Class 3 Multicast	69
31.3.1 Registration and De-registration	69
31.3.2 Multicast Routing	69
31.3.3 Class 3 Multicast rules	70
31.4 Broadcast	70
31.5 Moviecast	70
31.6 Other	71
32 Aliases	72
33 Dedicated Simplex	72
34 Class 4- Fractional	72
35 Camp-On	72
36 Stacked Connect Request	72
37 Buffered Class 1 Service	72
38 Data Compression	72
39 Clock synchronization service	73

	Page
39.1 Introduction	73
39.1.1 Applicability	73
39.1.2 Function	73
39.2 Communications Model	73
39.3 Requirements	74
39.3.1 Server Rules	74
39.3.2 Client Rules	74
39.4 Clock Synchronization Control	75
39.4.1 Use of FC-PH Constructs	75
39.4.1.1 Login/Logout	75
39.4.1.1.1 Initiator Capability	75
39.4.1.1.2 Recipient Capability	75
39.4.1.2 Exchanges	75
39.4.1.3 Information Units	75
39.4.1.4 Common Required FC Parameters	75
39.4.1.5 Common Optional FC Parameters	76
39.4.1.6 CT_HDR	76
39.4.2 Clock Control Request	76
39.4.3 Clock Control Link Service	76
39.4.3.1 Clock Control (CSS_CC)	77
39.5 Synchronize Clock Request	77
39.5.1 Primitive Signal Service	77
39.5.1.1 Terms	77
39.5.1.2 Synchronize Clock Request	78
39.5.1.3 Synchronize Clock Accept	78
39.5.1.4 Primitive Signal Insertion	78
39.5.2 ELS Service	78
39.5.2.1 Synchronize Clock Link Service	78
39.5.2.2 Synchronize Clock (CSS_SC)	78
40 Data Encryption	80
40.1 Introduction	80
40.2 N_Port Login	80
40.2.1 Initiator Capability	80
40.2.2 Recipient Capability	80

	Page
40.2.3 F_CTL	80
40.3 Applicability	80
40.4 Decryption	80
Annexes	
A	81
B	81
C	81
D	81
E	81
F	82
G	86
H	86
I	86
J	86
K	86
L	86
M	86
N	86
O	86
P	86
Q	87
R	87
S	88
T	90
U	90
V	90
W	90
X	90
Y	90
Z	90
AA	90
AB	90
AC	91
AD	100

	Page
AE	102

Tables

1	FC-0 physical links for electrical cable classes	6
2	FC-0 physical links for electrical cable classes (continued)	7
3	Eye diagram mask at point-S	10
4	Eye diagram mask at point-R'	10
5	Optional intercabinet contact uses	15
6	LV-style cable plant	17
7	TV-style cable plant	17
8	MI-style cable plant	18
9	TP-style cable plant	19
10	TW-style cable plant	19
11	Well-known Address identifiers	22
12	Type codes - FC-4 (Device_Data and Link_Data)	22
13	(Page 1 of 2) - F_CTL field	23
14	(Page 2 of 2) - F_CTL field	24
15	Data encryption status	25
16	DF_CTL bit definition	26
17	Priority/Preemption enabled	26
18	Priority/Preemption not enabled	26
19	NAA identifiers	28
20	Association_Header Validity bits (Bits 63-56)	29
21	P_BSY Reason Codes	30
22	P_RJT or F_RJT Reason Codes	30
23	Basic Link Service Commands	31
24	Extended Link Service Commands	32
25	Extended Link Service Commands	33
26	RTV Payload	34
27	RTV Accept Payload	34
28	LS_RJT reason code explanation	35
29	RNC/ACC Payload	36
30	Capability Entry	37
31	Document Identifiers	38
32	Responses to FLOGI frame (S_ID = 0 or 0000yy) - Fabric Login	44
33	N_Port Common Service Parameter Applicability	47

	Page
34 FC-PH-3 Version	48
35 N_Port Class Service Parameter Applicability	50
36 N_Port Class Service Parameter Applicability	51
37 Exchange Status Block	59
38 Sequence Status Block	59
39 Responses to Preemption Requests	64
40 CSS_CC Payload	77
41 CSS_CC Accept Payload	77
42 Data Character Translation	78
43 CSS_SC Payload	78
44 CSS_SC Accept Payload	79

Figures

1	Document relationship	xx
2	Fabric Regions	3
3	FC-4 Regions	4
4	FC-0 with 75W unbalanced cable	8
5	Unbalanced transmitter test circuit	9
6	Eye diagram mask at point-S	10
7	Eye diagram mask at point-R'	10
8	FC-0 with 150W balanced cable link	12
9	Balanced transmitter test circuit	12
10	Style-1 balanced connector pin assignments	12
11	Style-2 plug	13
12	Style-2 receptacle	14
13	Style-2 balanced connector receptacle pin locations	15
14	Balanced cable wiring	19
15	Optional headers order	28
16	Association_Header	29
17	FLOGI, PLOGI, or ACC Payload	45
18	N_Port Common Service Parameters - Fabric Login	48
19	N_Port Common Service Parameters - N_Port Login	49
20	N_Port Class Service Parameters - Fabric Login	52
21	N_Port Class Service Parameters - N_Port Login	53
22	F_Port Common Service Parameters - Fabric Login	54
23	F_Port Class Service Parameters - Fabric Login	55
24	Class 6 Multicast Routing	68
25	Class 3 Multicast Routing	70
26	Clock Synchronization Model	73
27	Real Time Loop Topology	91
28	Real Time Protocol Stack	92
29	Failure Detect and Re-routing	92
30	TDM Window	93

Foreword (This Foreword is not part of dpANS X3.xxx-199x.)

This Fibre Channel, Physical and Signalling Interface - 3 standard (FC-PH-3) describes the enhancements to the ANSI X3.230 FC-PH and X3.297 FC-PH-2 and is an addendum to both these documents.

This standard was developed by Task Group X3T11 of Accredited Standards Committee X3 during 1995-6. The standards approval process started in 1996. This standard includes annexes, which are informative, and are not considered part of the standard.

Requests for interpretation, suggestions for improvement or addenda, or defect reports are welcome. They should be sent to the X3 Secretariat, Information Technology Industry Council, 1250 Eye Street, NW, Suite 200, Washington, DC 20005.

NOTE: The developers of this standard have requested that holders of patents that may be required for the implementation of the standard, disclose such patents to the publisher. However neither the developers nor the publisher have undertaken a patent search in order to identify which if any patents may apply to this standard. No position is taken with respect to the validity of any claim or any patent rights that may have been disclosed. Details may be obtained from the publisher concerning any statement of patents and willingness to grant a license on a nondiscriminatory basis and with reasonable terms and conditions to applicants desiring to obtain such a license.

This standard was processed and approved for submittal to ANSI by Accredited Standard Committee on Information Processing Systems, X3. Committee approval of the standard does not necessarily imply that all committee members voted for approval. At the time it approved this standard, the X3 Committee had the following members:

TBD, Chair
TBD, Vice-Chair
TBD, Secretary

<i>Organization Represented</i>	<i>Name of Representative</i>
TBD.....	TBD
	TBD

Task Group X3T11 on Device Level Interfaces, which developed this standard, had the following participants:

Roger Cummings, Chair
Carl Zeitler, Vice-Chair
Bryan Cook, FC-PH-3 Technical Editor

Introduction

A set of advanced capabilities to FC-PH and FC-PH-2 are provided in FC-PH-3 to support some sophisticated application requirements. The advanced capabilities include features such as:

- Class 3 process policy
- Time distribution and clock synchronization
- E_D_TOV resolution enhancement
- Addition of new Extended Link Services:
 - Report Node Capability information
- Expanded copper media variants
- Class 6 service (Uni-directional Dedicated Connection)
- Priority and Preemption capabilities
- and others

These capabilities are accomplished by defining FC-3 Common Services, and enriching and complementing FC-2 Signaling protocol and FC-0 physical media and transceivers defined in FC-PH and FC-PH-2:

- FC-3 defines a set of services which are common across multiple ports of a node.
- FC-2 enhancements include E_D_TOV resolution refinements, Process error policy extensions, especially for Class 3, Time distribution, Clock synchronization, new Extended Link Service commands, and others.
- FC-0 enhancements define new variants for the copper media

Figure shows the relationship of this American National Standard (the highlighted rectangle) with other Fibre Channel standards and draft proposed standards. FC-PH-3 specifies the enhanced functions added to FC-PH, FC-PH-2. FC-FG and FC-SW are related to Fabric requirements. FC-AL specifies the arbitrated loop topology. FC-GS is related to Fibre Channel Services requirements. FC-IG provides some implementation guidance. FC-SB; ANSI X3.254, FC-FP; FC-LE; FC-ATM; IPI-3 Disk revision; IPI-3 Tape revision and SCSI-FCP are FC-4 standards.

FC-SB Mapping to Single Byte Command Code Sets	FC-LE Link Encapsulation	IPI-3 Disk Revision to IPI-3 Disk Std.	Other FC upper-layer protocols
FC-FP Mapping to HIPPI Framing Protocol	FC-ATM Mapping of ATM/AAL5	IPI-3 Tape Revision to IPI-3 Tape Std.	SCSI-FCP SCSI-3 Fibre Channel Protocol

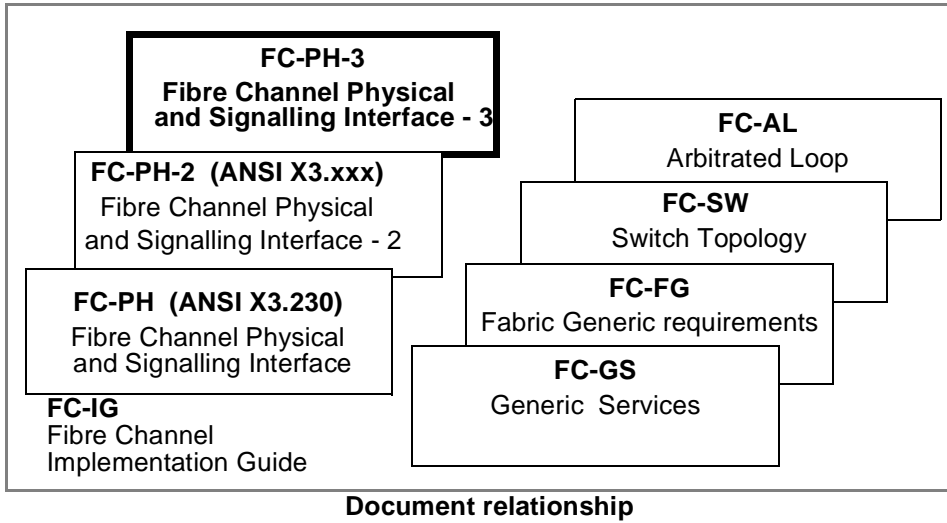

draft proposed American National Standard
for Information Technology—

Fibre Channel — Physical and Signalling Protocol - 3 (FC-PH-3)

1 Scope

FC-PH-3 describes the enhancement to the ANSI X3.230, FC-PH and to the ANSI X3.xxx, FC-PH-2 and is an addendum to the FC-PH and FC-PH-2 documents.

This document is an extension to the FC-PH and FC-PH-2 standards and describes a set of advanced capabilities beyond both FC-PH and FC-PH-2 to support more advanced and specialized applications.

2 Normative References

The following standards contain provisions which, through reference in this text, constitute provisions of this standard. At the time of publication, the editions indicated were valid. All standards are subject to revision, and parties to agreements based on this standard are encouraged to investigate the possibility of applying the most recent editions of the standards listed below.

Copies of the following documents can be obtained from ANSI: Approved ANSI standards, approved and draft international and regional standards (ISO, IEC, CEN/CENELEC, ITUT), and approved and draft foreign standards (including BSI, JIS, and DIN). For further information, contact ANSI Customer Service Department at 212-642-4900 (phone), 212-302-1286 (fax) or via the World Wide Web at <http://www.ansi.org>.

2.1 Approved references

ANSI X3.230-1994, *Fibre Channel Physical and Signalling Interface (FC-PH)*

ANSI X3T10/995D, *SCSI-3 Primary Commands*

ANSI X3.131-199x - *Small Computer System Interface (SCSI-2)*

X3.132-1990 - *Intelligent Peripheral Interface (IPI-3)*

X3.702D-199x - *High Performance Parallel Interface Framing Protocol (HIPPI-FP)*

2.2 References under development

At the time of publication, the following referenced standards were still under development. For information on the current status of the documents, or regarding availability, contact the relevant standards body or other organization as indicated.²

ANSI X3.xxx-199x, *Fibre Channel Physical and Signalling Protocol - 2 (FC-PH-2)*

ANSI X3.xxx-199x, *Fibre Channel-Fabric Requirements (FC-FG)*

ANSI X3.xxx-199x, *Fibre Channel-Arbitrated Loop (FC-AL)*

ANSI X3.xxx-199x, *Fibre Channel-Switch Topology (FC-SW)*

ANSI X3.xxx-199x, *Fibre Channel-SBCC Mapping Protocol (FC-SB)*

ANSI X3.xxx-199x, *Fibre Channel-Link Encapsulation (FC-LE)*

². For information about obtaining copies of these documents or more information on the current status of these documents, contact the X3 Secretariat at: <http://www.x3.org> or 202-626-5738.

3 Definitions and conventions

For FC-PH-3, the following definitions, conventions, abbreviations, acronyms, and symbols apply, in addition to those defined in X3.230-1994 (FC-PH) and X3.xxx-1995 (FC-PH-2).

3.1 Definitions

3.1.1 FC-4 Region

A set of N_Ports connected either point-to-point or to a common Fabric, such that any N_Port in the set can successfully complete the N_Port Login procedure with all other N_Ports in the set and successfully maintain an Exchange for a particular FC-4.

3.1.2 Profile

An interoperability specification that provides implementation guidelines for systems manufacturers, system integrators, component manufacturers, and users seeking to design and select interoperable Fibre Channel peripherals, hosts, and components. A Profile specifies particular settings for various Fibre Channel physical, link-level, and upper-level protocol options to enhance interoperability.

3.2 Editorial conventions

Enhancements to conventions defined in X3.230-1994 (FC-PH) and X3.xxx-1995 (FC-PH-2) are specified.

3.3 Abbreviations, acronyms and symbols

Abbreviations, acronyms and symbols applicable to this standard are listed. Definitions of several of these items are included in 3.1. The index at the back of the document is an aid to help locate these terms in the body of the document.

3.3.1 Acronyms and other abbreviations

NTP	Network Time Protocol
REQCS	Request Clock Synchronization
RNC	Report Node Capability
P_AS	Process_Associator
O_AS	Operation_Associator

4 Structure and concepts

This clause provides an overview of the structure, concepts, and mechanisms used in FC-PH-3 and is intended for informational purposes only.

4.16 FC-4 Regions

FC-FG defines a *Region* as a section of a Sub-Fabric such that all the N_Ports in that Region operate at the same data rate and the same Class of Service. Additionally, the N_Ports within the Region share the same Regional Service Parameters, e.g., address assignment mode, in-order frame delivery. Essentially, this means

that all N_Ports within a Region are able to successfully perform the PLOGI procedure with each other. Figure 110 illustrates a set of N_Ports across 2 Regions: N_Ports A, B, C, and D are in Region 1 because they all support Class 1 at 1 Gbit/second. N_Ports D, E, and F are in Region 2 because they all support Class 2 at 1 Gbit/second. Note that N_Port D is in both Regions.

However, just because a pair of N_Ports can execute a PLOGI-ACC with each other does not guarantee that they can successfully perform an FC-4 Exchange. For example, N_Port B that requires an Initial Process_Associator is not capable of communicating with N_Port A that does not support the Initial Process_Associator.

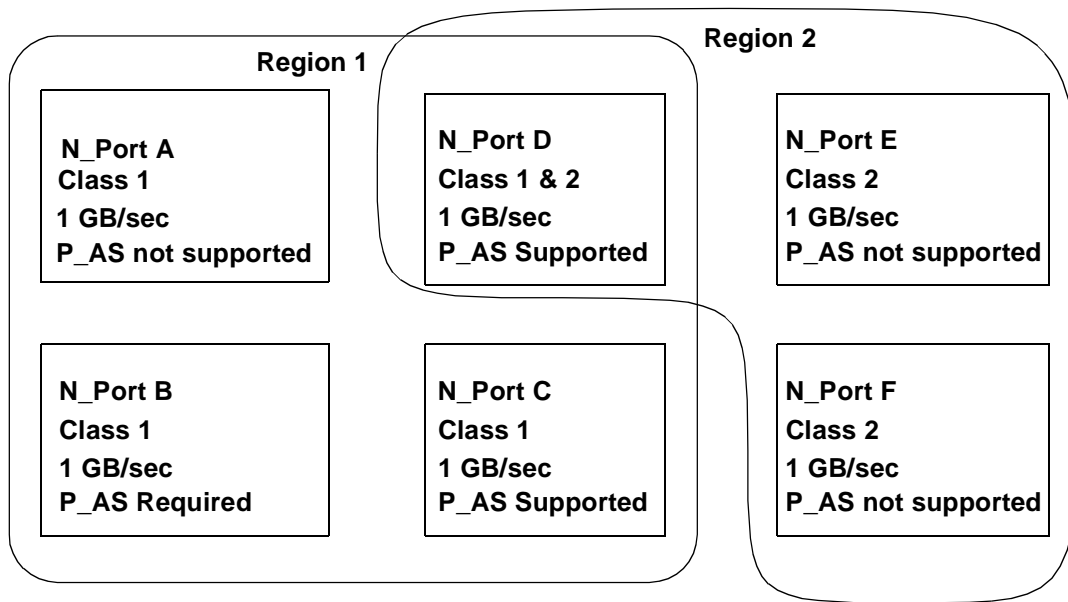

Figure 110 – Fabric Regions

Therefore, the term *FC-4 Region* is used to define a set of N_Ports within a Fabric Region which can successfully communicate via FC-4 Exchanges. That is, all their PLOGI Service Parameters are such that they can successfully originate an Exchange for the purpose of supporting an FC-4 protocol. Figure 111 illustrates the same set of N_Ports, now in 3 FC-4 Regions: N_Ports A, C, and D are in Region 1 because they all support Class 1 at 1 Gbit/second and they all will not use the Initial Process Associator, as determined by PLOGI. N_Ports D,

E, and F are in Region 2 because they all support Class 2 at 1 Gbit/second and they all will not use the Initial Process Associator, as determined by PLOGI. N_Ports B, C, and D are in Region 3 because they all support Class 1 at 1 Gbit/second and they all will use the Initial Process Associator, as determined by PLOGI.

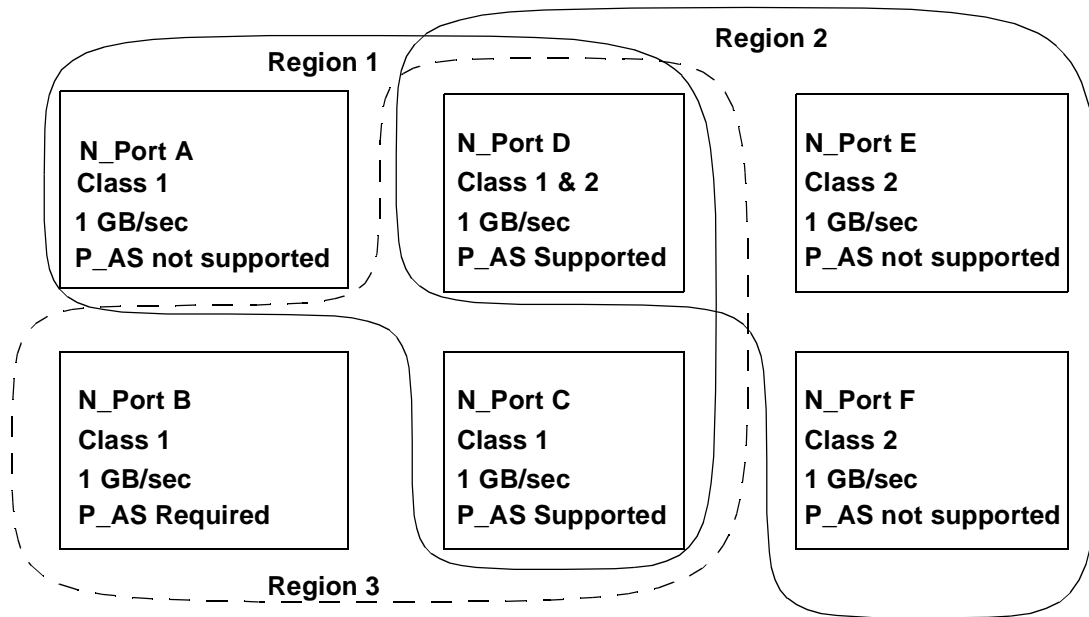

Figure 111 – FC-4 Regions

5 FC-0 functional characteristics

The third unordered list item in 5.1 is replaced as described.

5.1 General Characteristics

FC-0 has the following general characteristics:

- No change from FC-PH.
- No change from FC-PH-2.
- The FC-2 protocol is designed to operate across connections having a BER detected at the receiving node of 10^{-12} . It shall be the combined responsibility of the component vendors and the system integrator to ensure that this level of service is provided in a given Fibre Channel installation.

6 Optical fibre interface specification

No enhancements from X3.230-1994 (FC-PH) or x3.xxx-1995 (FC-PH-2).

7 Electrical cable interface specification

This clause defines the interfaces of the serial electrical signal at the interconnect receptacles. Each conforming electrical FC attachment shall be compatible with this serial electrical interface to allow interoperability within an FC environment. All Fibre Channel links described in this clause shall operate within the BER objective (10^{-12}). The parameters specified in this clause

support meeting that requirement under all conditions including the minimum input and output amplitude levels. The corresponding cable plant specifications are described in clause 9.

The link distance capability specified in table 10 is based on insuring interoperability across multiple vendors supplying the technologies (both link transceivers and cable plants) under the tolerance limits specified in the document. Links

Table 10 – FC-0 physical links for electrical cable classes

FC-0	Units	100-LV-EL-S 100-TV-EL-S 100-MI-EL-S 100-TP-EL-S 100-TW-EL-S	50-LV-EL-S 50-TV-EL-S 50-MI-EL-S 50-TP-EL-S 50-TW-EL-S	25-LV-EL-S 25-TV-EL-S 25-MI-EL-S 25-TP-EL-S 25-TW-EL-S	12-LV-EL-S 12-TV-EL-S 12-MI-EL-S 12-TP-EL-S 12-TW-EL-S
Data Rate	MB/s.	100	50	25	12,5
Nominal Bit Rate	MBaud	1 062,5	531,25	265,625	132,812 5
Tolerance	ppm	±100	±100	±100	±100
Operating Distance					
Intracabinet					
LV	meters	0-24	0-33	0-47	0-67
TV	meters	0-20	0-28	0-40	0-56
MI	meters	0-5.6	0-7.6	0-11	0-16
TP	meters	0-11	0-16	0-22	0-32
TW	meters	0-13	0-18	0-26	0-37
Intercabinet					
LV	meters	0-59	0-84	0-100	0-100
TV	meters	0-50	0-71	0-100	0-100
MI	meters	0-14	0-19	0-28	0-42
TP	meters	0-28	0-40	0-57	0-80
TW	meters	0-33	0-46	0-66	0-93
Cable Impedance					
LV	Ω(nom.)	75	75	75	75
TV	Ω(nom.)	75	75	75	75
MI	Ω(nom.)	75	75	75	75
TP	Ω(nom.)	150	150	150	150
TW	Ω(nom.)	150	150	150	150
Link Impedance @ S'					
TDR Rise Time	ps	100	200	400	800
Exception Window	ps	800	1000	1200	1400
Through Connection					
Unbalanced	Ω	75±15	75±15	75±15	75±15
Balanced	Ω	150±30	150±30	150±30	150±30
Cable					
Unbalanced	Ω	75±5	75±5	75±5	75±5
Balanced	Ω	150±10	150±10	150±10	150±10

Table 10 – FC-0 physical links for electrical cable classes (continued)

FC-0	Units	100-LV-EL-S	50-LV-EL-S	25-LV-EL-S	12-LV-EL-S
		100-TV-EL-S	50-TV-EL-S	25-TV-EL-S	12-TV-EL-S
		100-MI-EL-S	50-MI-EL-S	25-MI-EL-S	12-MI-EL-S
		100-TP-EL-S	50-TP-EL-S	25-TP-EL-S	12-TP-EL-S
		100-TW-EL-S	50-TW-EL-S	25-TW-EL-S	12-TW-EL-S
Transmitter (S)	Output characteristics at the cable connector (when transmitting any primitive signal or sequence)				
Type		ECL/PECL	ECL/PECL	ECL/PECL	ECL/PECL
Amplitude					
Intracabinet					
Max	mV(p-p)	1600	1600	1600	1600
Min	mV(p-p)	600	600	600	600
Intercabinet					
Max	mV(p-p)	2000	2000	2000	2000
Min	mV(p-p)	1100	1100	1100	1100
Deterministic Jitter	%(p-p)	10	10	10	10
Random Jitter	%(p-p)	12	12	8	8
Rise/Fall Time 20-80%					
maximum	ps	385	772	1540	3020
minimum	ps	100	200	400	800
Imbalance					
Skew	ps	25	50	100	200
Receiver (R)	Input characteristics at the cable connector (when receiving any primitive signal or sequence)				
Minimum Sensitivity	mV(p-p)	400	400	400	400
Input Impedance @ R					
TDR Rise Time	ps	100	200	400	800
Exception Window	ps	800	1000	1200	1400
Through Connection					
Unbalanced Inputs	Ω	75±15	75±15	75±15	75±15
Balanced Input	Ω	150±30	150±30	150±30	150±30
At Termination					
Unbalanced Inputs	Ω	75±5	75±5	75±5	75±5
Balanced Inputs	Ω	150±10	150±10	150±10	150±10
Differential Skew	ps	200	400	800	1600

operating at these maximum distances may require some form of equalization in the cable plant to meet all link requirements. Greater link distances may be obtained by specifically engineering a link based on knowledge of the technology characteristics and the conditions under which the link is installed and operated. However, such link distance extensions are outside the scope of this standard.

The user needs to take care that their use conditions at least conform to the specified signal conditions of the document

7.1 Electrical data links

The electrical data link definitions apply to all styles of unbalanced cable (the 75 Ω LV, TV, and MI style coax), and balanced cable (the 150 Ω TP and TW cables). The electrical characteristics of these links are defined in tables 10, 11, and 12, and in figures 29 and 30.

The operating distance limits listed in table 10 are based on the minimum launch amplitude, delivered to a receiver requiring the minimum input amplitude, through a cable having the loss characteristics listed in clause 9.

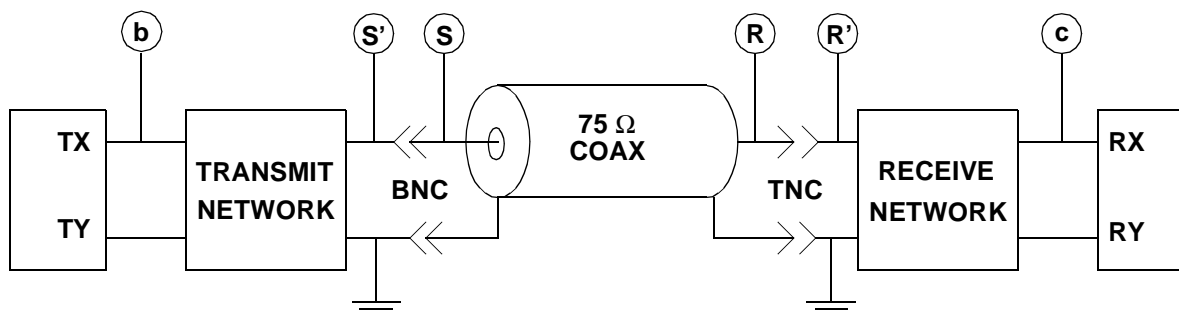

Figure 27 – FC-0 with 75Ω unbalanced cable

NOTE – All specifications, unless specifically listed otherwise, are based on differential measurements.

NOTE – All times indicated for TDR measurements are recorded times. Recorded times are twice the transit time of the TDR signal.

NOTE – The transmit imbalance skew and receiver differential skew are the maximum allowed time difference (on both low-to-high and high-to low transitions) between the true and complement signals. This time difference is measured at the mid-way point on the signal swing of the true and complement signals. These are single ended measurements.

NOTE – The transmitter imbalance skew measurement is only valid for balanced driver configurations. It defines the maximum timing difference, as measured at point-S, of the true and complement signals generated by the balanced media driver. The differential skew specification at the receiver consists of this same measurement made at point-R'. The receiver skew requirement assumes a combined maximum transmitter and maximum cable skew.

NOTE – The link impedance measurement identifies the impedance mismatches present in the cable plant when terminated in its characteristic impedance. This measurement includes mated connectors at both ends of the cable (points S'/S and R/R') and any intermediate connectors or splices between these locations. The link termination shall match that shown in figures 28 and 32.

NOTE – The exception window used with specific impedance measurements identifies the maximum time period during which the measured impedance is allowed to exceed the listed impedance tolerance.

NOTE – The maximum excursion within the exception window at points-S' and -R shall not exceed ±33% of the nominal cable impedance.

NOTE – The link impedance at point-S', for the cable, shall be recorded 4,0 ns following the reference location determined by an open connector between point-S and S'.

NOTE – The input impedance at point-R, for the termination, shall be recorded 4,0 ns following the reference location determined by an open connector between point-R and R'

NOTE – The transmitter amplitude maximum specification identifies the maximum p-p signal that can be delivered into a resistive load matching that shown in figures 28 and 32.

NOTE – The transmitter amplitude minimum specification identifies the minimum allowed p-p eye amplitude opening that can be delivered into a resistive load matching that shown in figures 28 and 32.

NOTE – The transmitter jitter specifications are presently under review and may change in a future release of this standard.

NOTE – The receiver sensitivity identifies the minimum p-p eye amplitude at point-R to meet the BER objective.

NOTE – The maximum operable distance for a specific link type is calculated by dividing the loss per meter at the half-Baud frequency (listed in clause 9), into the available link-loss budget. This loss budget is calculated as $20\log(\text{output_amplitude}/\text{min_input_amplitude})$ for a specific link implementation.

All styles of unbalanced (coaxial) cables are interoperable; i.e., electrically compatible with minor impact on link-length capability when intermixed. The balanced (TP and TW) cables are also interoperable. Interoperability implies that the transmitter and receiver level specifications, as measured in figures 27 and 31, and defined in tables 10, 11, and 12, are preserved with the trade-off being distance capability in an intermixed system. Other electrically compatible, interoperable unbalanced or balanced cables may be used to achieve goals of longer distance, higher data rate, or lower cost as desired in the system implementation, provided that they are connector, impedance, and propagation mode compatible.

The balanced cables are incompatible with unbalanced cables in terms of characteristic impedance, mode of connection to the transceiver, and other electrical and mechanical parameters. Different connectors are specified for balanced and unbalanced cables to avoid user mixing.

Schematics in the diagrams in this clause are for illustration only and do not represent the only feasible implementation. The links described in this clause shall be applied only to homogenous ground applications such as between devices within a cabinet or rack, or between cabinets interconnected by a common ground return or ground plane. This restriction minimizes safety and interference concerns caused by any voltage differences that could otherwise exist between equipment grounds.

The recommended interface to electrical transmission media is via transformer coupling for inter-cabinet connections and via capacitive coupling for intracabinet connections.

7.2 Reference locations

All interface specifications are only valid at the point of entry and exit from the equipment. These points are identified as point-S, -S', -R, and -R' in all related tables and figures. This assumes that all measurements are made after a mated connector pair, relative to the source or destination.

7.2.1 Intercabinet references

The reference points for all connections between cabinets are those points-S, -S', -R, and -R' where the cabinet Faraday shield transitions between the cabinet and the cable shield. If sections of transmission line exist within the Faraday shield, they are considered to be part of the associated transmit or receive network, and not part of the cable plant.

7.2.2 Intracabinet references

The reference points for all connections within a cabinet are those points-S, -S', -R, and -R' where the serial data signal passes through its first mateable connector.

7.3 75 Ω unbalanced data links

7.3.1 ECL compatible driver characteristics

The output driver is assumed to have output levels approximating those of Emitter Coupled Log-

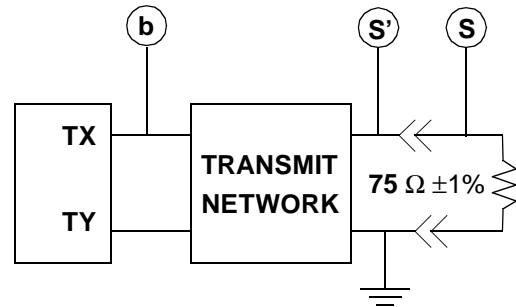

Figure 28 – Unbalanced transmitter test circuit

ic (ECL), as measured at point-b. For all inter-cabinet links, the output driver shall be AC coupled to the cable through a transmission network, and have output levels, measured at the input to the cable (point-S), as listed in table 11, when terminated as shown in figure 28. For all intracabinet links the driver may be either AC or DC-coupled to the media.

The mask of the transmitter eye diagram is given in figure 29. The normalized transmitter output timing and differential amplitude requirements are specified in tables 10 and 11.

The Y1 and Y2 amplitudes in table 11 are set to allow signal overshoot of 10% and undershoot of 20%, relative to the amplitudes determined to be a logic 1 and 0.

NOTE – The normalized 1 is that amplitude determined to be the average amplitude when driving a logic 1. The normalized 0 is that amplitude determined to be the average amplitude when driving a logic 0.

7.3.2 ECL compatible receiver characteristics

The receiver shall be AC-coupled to the media through a receive network located between points-R and -c as shown in figure 27. The receive network shall terminate the link by an equivalent impedance of 75 Ω .

An optional equalizer network, when present in a link, shall exist and operate as part of the cable plant. It shall be used to correct for frequency selective attenuation loss of the transmitted signal, as well as timing variations due to the differences in propagation delay time between higher and lower frequency components. An equalizer should need no adjustment. A more detailed discussion of an equalizer is found in Annex F.

Table 11 – Eye diagram mask at point-S

Bit rate (Mbaud)	Normalized Time		Normalized Amplitude		Intracabinet Differential Amplitude		Intercabinet Differential Amplitude	
	X1	X2	Y1	Y2	A (minimum)	B (maximum)	A (minimum)	B (maximum)
132,818 5	0,09	0,29	0,2	0,1	300 mV	800 mV	550 mV	1000 mV
265,625	0,09	0,29	0,2	0,1	300 mV	800 mV	550 mV	1000 mV
531,25	0,11	0,30	0,2	0,1	300 mV	800 mV	550 mV	1000 mV
1 062,5	0,11	0,30	0,2	0,1	300 mV	800 mV	550 mV	1000 mV

The receiver shall operate within the BER objective (10^{-12}) when an unbalanced data link is driven by a transmitter meeting the requirements defined in tables 10, 11, and figure 29, and a signal is delivered to the receiver meeting the eye diagram requirements specified in table 12 and figure 30.

The unbalanced data link characteristics of maximum path penalty and input impedance of the receiver are specified in table 10.

The mask of the receiver eye diagram is given in figure 30. The receiver input is specified in table 12.

NOTE – The receiver (at point-c) must accommodate 10% of a bit period more total jitter than that listed in table 12. This 10% jitter allocation is to allow for any external EMI induced events.

NOTE – The minimum input amplitude to the receiver listed in table 12 is a worst case specification across all environmental conditions. Restricted environments may allow operation at lower minimum differential voltages, allowing significantly longer operating distances.

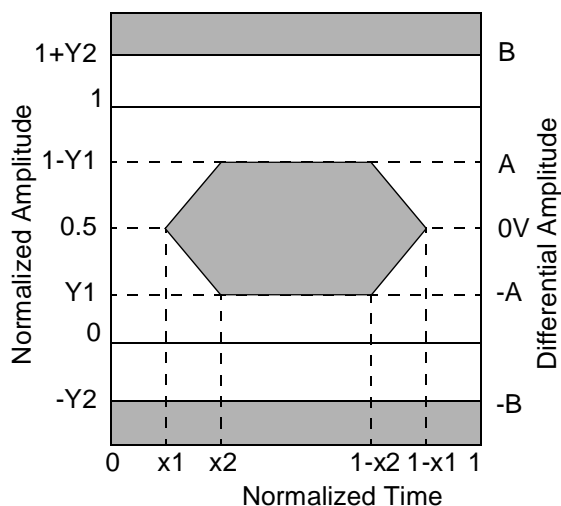

Figure 29 – Eye diagram mask at point-S

Table 12 – Eye diagram mask at point-R'

Bit rate (Mbaud)	X1	X2	Y1	Y2
132,818 5	0,30	0,6	200 mV	1000 mV
265,625	0,30	0,6	200 mV	1000 mV
531,25	0,30	0,6	200 mV	1000 mV
1 062,5	0,30	0,6	200 mV	1000 mV

7.3.3 Unbalanced cable characteristics

The 75Ω unbalanced data links may be interconnected using any specified unbalanced cable depending on the performance and distance required for a specific application.

The cable shield(s) shall be grounded through the bulkhead connectors on both the transmitter and receiver ends as shown in figure 27.

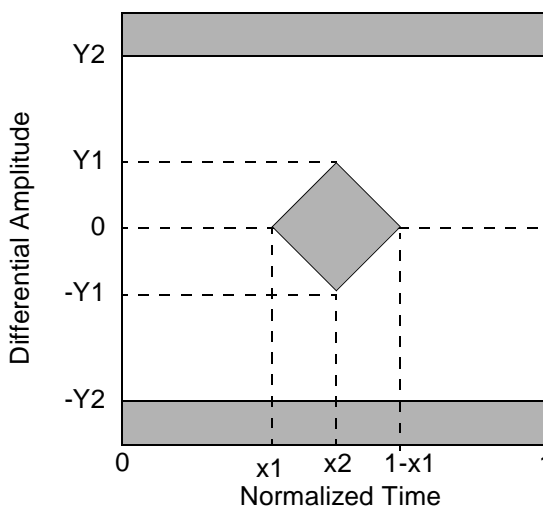

Figure 30 – Eye diagram mask at point-R'

7.3.4 Unbalanced cable connectors

7.3.4.1 Intercabinet connectors for unbalanced cable

Connections between cabinets require the use of shielded cable assemblies, terminated in polarized shielded connectors. All unbalanced cable types shall be connected using either style-1 or style-2 unbalanced connectors.

Standard cable assemblies shall have either proper varieties of style-1 connectors at both ends of the cable, or style-2 connectors at both ends of the cable. Cables may also be constructed with both a style-1 and style-2 connector for use in mixed installations or to adapt from one style to the other.

The cable connector shall be the plug or male connector while the bulkhead connector shall be the receptacle or female connector.

7.3.4.2 Style-1 unbalanced cable connector

The style-1 connectors for unbalanced cable shall be industry standard 75Ω BNC and TNC type connectors, as shown in figure 27. The electrical performance of the 75Ω BNC and TNC connectors shall be compatible with video style connectors specified by IEC 169-8 and IEC 169-17.

The mechanical compatibility for BNC type (bayonet lock coupling) connectors is defined by IEC 169-8. The mechanical compatibility for TNC type (threaded coupling) connectors is defined by IEC 169-17. Primary use of unbalanced cables are for interconnection of cabinets.

These two connector types (BNC and TNC) are specified to provide polarization to prevent the incorrect connection of transmitter-to-transmitter or receiver-to-receiver. The end of such a cable, connected to an unbalanced transmitter, shall be implemented with a male BNC-type connector and the receiving end shall be implemented with a male TNC-type connector. The transmitter and receiver shall be implemented using female BNC and TNC type connectors respectively.

Should a case occur where, through a cabling error or the incorrect use of in-line splices or other adapters, two transmitters or receivers are directly connected, no damage shall occur to any transmitter, receiver, or other link component in the system. The link shall be able to withstand

such an invalid connection without component failure or degradation for an indefinite period of time.

7.3.4.3 Style-2 unbalanced cable connector

The style-2 connectors for unbalanced cable shall be industry standard 50Ω SMA. The electrical performance of the 50Ω SMA connectors shall be compatible with IEC 169-15.

The mechanical compatibility for SMA-type connectors is defined by IEC 169-15. Primary use of unbalanced cables are for interconnection of cabinets.

Both ends of such a cable shall be implemented with a male SMA-type connector. The transmitter and receiver shall be implemented using female SMA-type connectors.

Should a case occur where, through a cabling error or the incorrect use of in-line splices or other adapters, two transmitters or receivers are directly connected, no damage shall occur to any transmitter, receiver, or other link component in the system. The link shall be able to withstand such an invalid connection without component failure or degradation for an indefinite period of time.

7.3.4.4 Intracabinet connectors for unbalanced cable

Connections within a cabinet do not normally require the same level of shielding as connections external to a cabinet. For these internal connections an alternate connector may be used that interfaces with industry standard headers with 0,64 mm (0,025 in) square posts on 2,54 mm (0,100 in) center spacing. Due to size constraints this connector is only intended to be used with the miniature coaxial cable.

These connectors are generally not entirely shielded and leakage of RFI may occur. A shielded cabinet and/or other RF leakage control techniques such as ferrite beads or lossy tubing are recommended for compliance with EMC standards, even with double shielded cables (refer to Annex F).

7.4 150Ω balanced data links

7.4.1 ECL compatible driver characteristics

The output driver is assumed to have Emitter Coupled Logic (ECL) output levels, as mea-

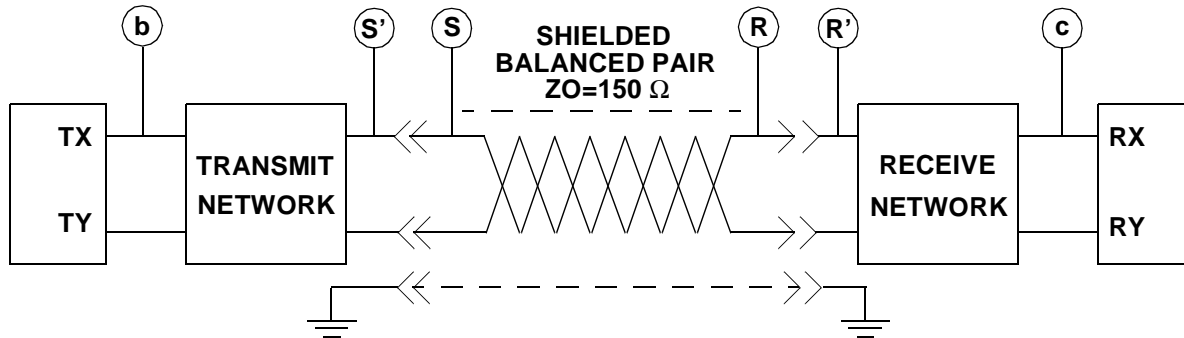

Figure 31 – FC-0 with 150Ω balanced cable link

sured at point-b. For all intercabinet links, the output driver shall be AC-coupled to the media through a transmission network, and have complementary outputs with outputs levels, measured at the input to the media (point-S) as listed in tables 10 and 11, when terminated as shown in figure 32. For all intracabinet links the driver may be either AC- or DC-coupled to the media. Measurements are to be made using an oscilloscope whose bandwidth including probes is at least 1,8 times the Baud rate.

The mask of the transmitter eye diagram is given in figure 29. The transmitter output is specified in tables 10 and 11.

7.4.2 ECL compatible receiver characteristics

The receiver shall be AC-coupled to the media through a receiver network located between points-R' and -c as shown in figure 31. The receive network shall terminate the link by an equivalent impedance of 150Ω.

An optional equalizer network, when present in a link, shall exist as part of the cable plant. It shall be used to correct for timing variations due to the differences in propagation delay time be-

tween higher and lower frequency components, as well as frequency selective attenuation loss of the transmitted signal. An equalizer should need no adjustment. A more detailed discussion of the equalizer is found in Annex F.

The receiver shall operate within the BER objective (10^{-12}) when a balanced data link is driven by a transmitter meeting the requirements defined in tables 10, 11, and figure 29, and a signal is delivered to the receiver meeting the eye diagram requirements in table 12 and figure 30.

The balanced data link characteristics of maximum path penalty and input impedance of the receiver are specified in table 10.

The mask of the receiver eye diagram is given in figure 30. The receiver input is specified in table 12.

NOTE – The receiver (at point-c) must accommodate 10% of a bit time more total jitter than that listed in table 12. This 10% jitter allocation is to allow for any external EMI induced events.

7.4.3 Balanced cable characteristics

The 150Ω balanced links may be interconnected using either TP or TW cable, depending on the performance, distance, or application required for a specific link.

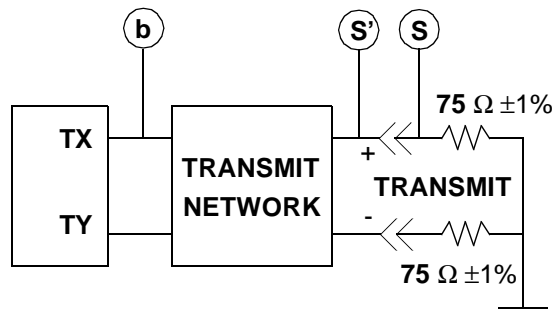

Figure 32 – Balanced transmitter test circuit

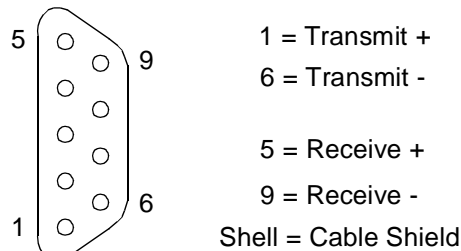

Figure 33 – Style-1 balanced connector pin assignments

Cable shield(s) shall be grounded through the bulkhead connector shell(s) on both the transmitter and receiver ends as shown in figure 31.

7.4.4 Balanced cable connectors

7.4.4.1 Intercabinet connectors for balanced cable

Connections between cabinets require the use of shielded cable assemblies, terminated in polarized shielded connectors. Both the TP and TW cable types shall be connected using either the style-1 or style-2 balanced cable connectors.

Standard cable assemblies shall have either style-1 connectors at both ends of the cable, or style-2 connectors at both ends of the cable. Cables may also be constructed with both a style-1 and style-2 connector for use in mixed connector installations or to adapt from one style to the other.

The cable connector shall be the plug or male connector while the bulkhead connector shall be the receptacle or female connector.

7.4.4.2 Style-1 balanced cable connector

The style-1 connector for balanced cables is the 9-pin shielded D-subminiature connector conforming to IEC 807-3. The plug (male) half of the connector shall be mounted on the cable. One connector is required to connect both

transmitting and receiving shielded pairs at one node. The connector pin assignments are shown in figure 33. Unused pin positions within the connector body are reserved.

The electrical conformance and mechanical compatibility for D-subminiature type connectors is defined by IEC 807-3.

Should a case occur where, through a cabling error or the incorrect use of in-line splices or other adapters, two transmitters or receivers are directly connected, no damage shall occur to any transmitter, receiver, or other link component in the system. The link shall be able to withstand such an invalid connection without component failure or degradation for an indefinite period of time.

7.4.4.3 Style-2 balanced cable connector

The style-2 connector for balanced cables is dimensionally defined by figures 34 and 35. The connector pin assignments are shown in figure 36.

Should a case occur where, through a cabling error or the incorrect use of in-line splices or other adapters, two transmitters or receivers are directly connected, no damage shall occur to any transmitter, receiver, or other link component in the system. The link shall be able to withstand such an invalid connection without

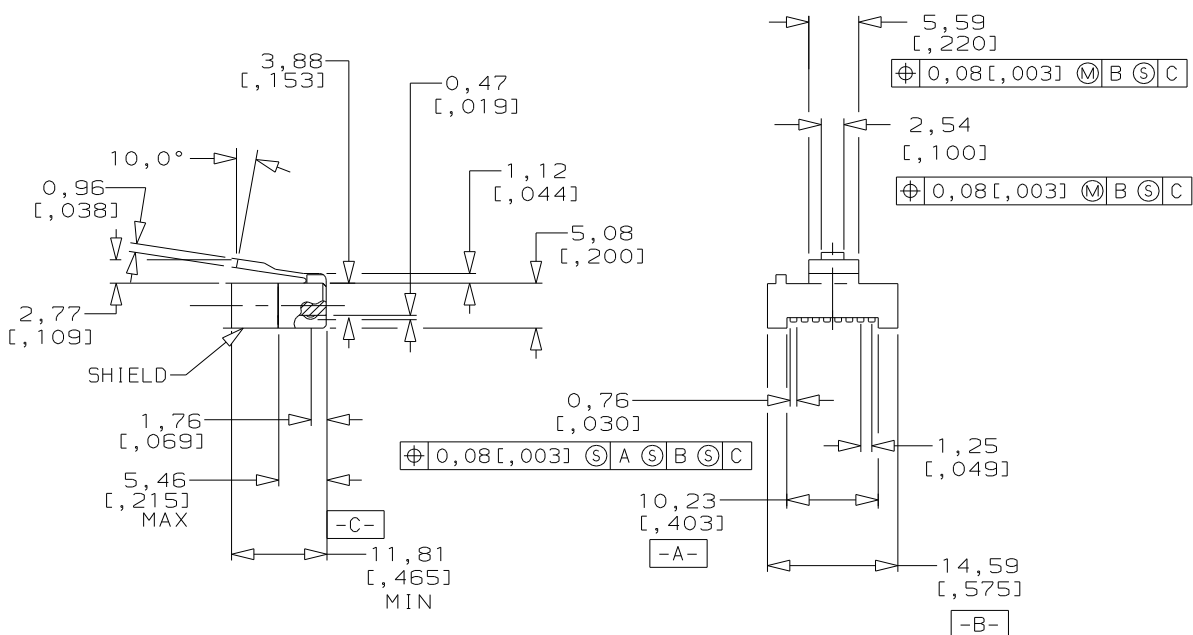

Figure 34 – Style-2 plug

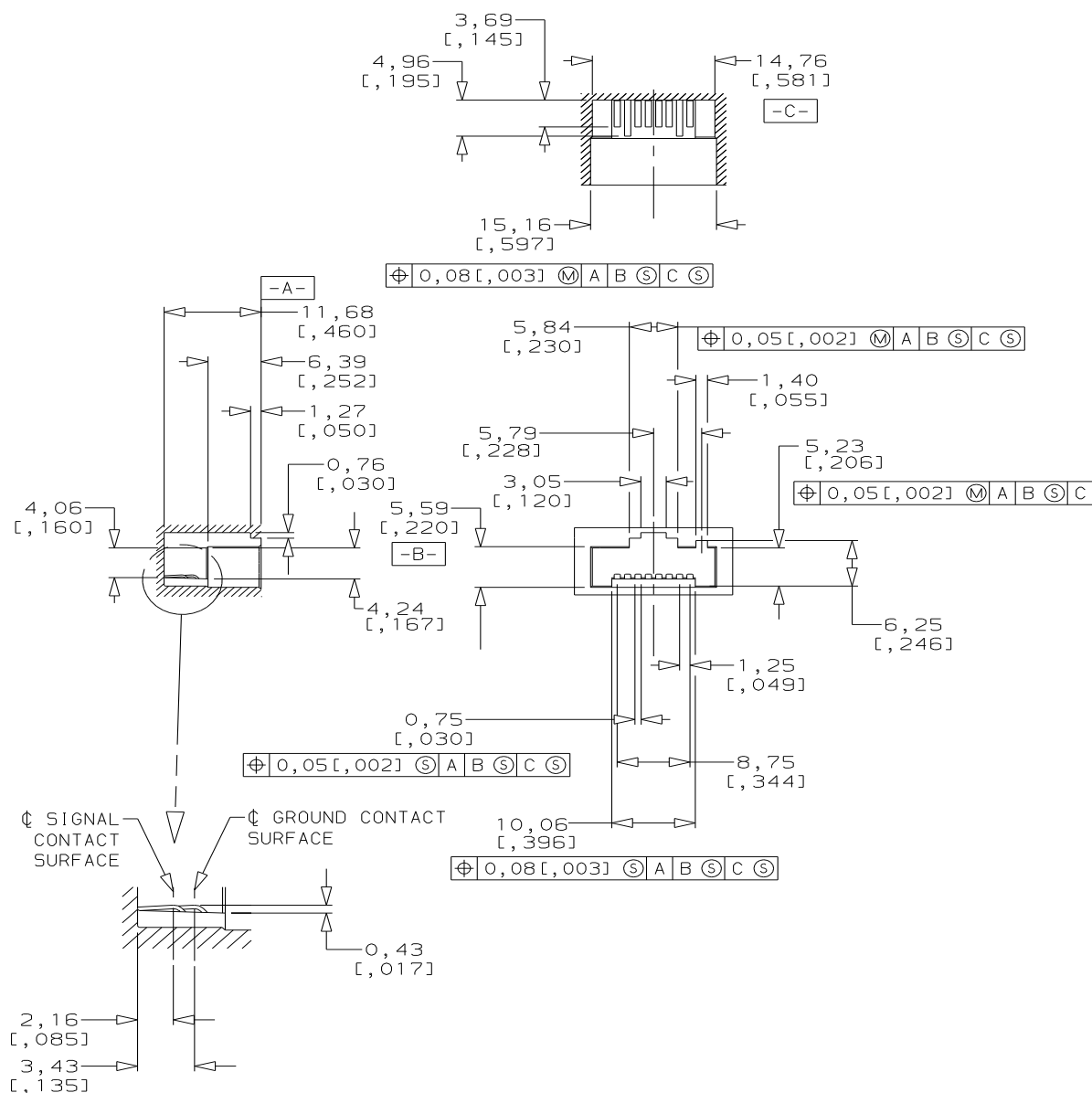

Figure 35 – Style-2 receptacle

component failure or degradation for an indefinite period of time.

7.4.4.3.1 Style-2 plug

The plug (male) half of the connector shall be mounted on the cable. One connector is required to connect both the transmitting and the receiving shielded pairs at one node. The style-2 plug is dimensionally defined in figure 34.

7.4.4.3.2 Style-2 receptacle

The style-2 receptacle is dimensionally defined in figure 35. This connector mates with both transmit and receive balanced pairs. Unused pin

positions within the connector body are reserved. The connector contains eight pin locations plus an external shield. Pin locations 1, 3, 6, and 8 shall be populated in the connector body.

7.4.4.4 Optional intercabinet connector pins

Both styles of intercabinet connectors may be populated with additional contacts to support additional functions. The presence of such contacts in the connector assemblies does not imply support for additional functions.

The suggested use for these additional contacts or contact locations is listed in table 12 .

Table 13 – Optional intercabinet contact uses

Contact Name	Pin Number	
	Style 1	Style 2
Power supply, nominal +5VDC	2	7
Module fault detect	3	4
Mechanical key	4	
Output disable	7	5
Signal ground/+5VDC return	8	2

7.4.4.5 Intracabinet connectors for balanced cable

Connections within a cabinet do not normally require the same level of shielding as connections external to a cabinet. For these internal connections an alternate connector may be used that interfaces with industry standard headers with 0,64 mm (0,025 in) square posts on 2,54 mm (0,100 in) center spacing. Due to size constraints this connector is only intended to be used with TW cable.

These connectors are not entirely shielded and leakage of RFI may occur. A shielded cabinet and/or other RF leakage control techniques such as ferrite beads or lossy tubing is recommended for compliance with EMC standards, even with double shielded balanced cables (refer to Annex F).

7.4.4.6 Intracabinet connectors for balanced cable

Connections within a cabinet do not normally require the same level of shielding as connections external to a cabinet. For these internal connections an alternate connector may be used that interfaces with industry standard headers with 0,64 mm (0,025 in) square posts on 2,54 mm (0,100 in) center spacing. Due to size constraints this connector is only intended to be used with TW cable.

tions an alternate connector may be used that interfaces with industry standard headers with 0,64 mm (0,025 in) square posts on 2,54 mm (0,100 in) center spacing. Due to size constraints this connector may not assemble well with all variations of balanced cable.

These connectors are generally not entirely shielded and leakage of RFI may occur. A shielded cabinet and/or other RF leakage control techniques such as ferrite beads or lossy tubing are recommended for compliance with EMC standards, even with double shielded cables (refer to Annex F).

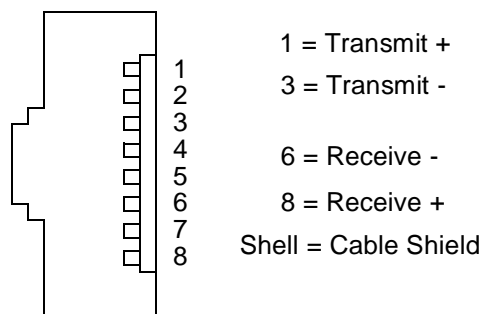

Figure 36 – Style-2 balanced connector receptacle pin locations

dpANS X3.xxx-199x

8 Optical fibre cable plant specification

No enhancements from X3.230-1994 (FC-PH) or x3.xxx-1995 (FC-PH-2).

9 Electrical cable plant specification

This clause defines the link requirements for a Fibre Channel electrical cable plant.

9.1 Unbalanced cable plant

The unbalanced cables listed in this clause are not the only such cables that may be used to create such links. Usage of other cables are permitted to meet specific cost, performance, or other implementation specific criteria.

When using such cables it is the implementer's responsibility to insure that all impedance, attenuation (loss), jitter, and shielding are within the operating limits of the link type and data rate being implemented.

9.1.1 LV (long-video) cable plant specification

This subclause specifies a LV-style cable plant which is capable of communication at data rates specified in table 15. The cable plant is generally insensitive to data rate and therefore any installed portions of the cable plant may be used at any data rate.

Table 14 – LV-style cable plant

FC-0	Unit	100-LV-EL-S	50-LV-EL-S	25-LV-EL-S	12-LV-EL-S
Subclause		7.3	7.3	7.3	7.3
Attenuation (nom.) at Baudrate/2 equivalent frequency	dB/m	0,148	0,105	0,074	0,052
Connector Related Loss	dB/conn	0,25	0,25	0,25	0,25
Impedance	Ω	75	75	75	75
Impedance Tolerance	$\pm\Omega$	5	5	5	5

For those cables containing embedded equalization circuits, the operation of the cable may be both data rate and length specific. All cables containing such circuits shall be marked with in-

formation identifying the specific designed operational characteristics of the cable assembly.

NOTE – The Baudrate/2 equivalent frequency for any specific data rate (referenced in tables in this clause) is the frequency of the square wave produced when continuously transmitting a D21.5 transmission character.

9.1.1.1 LV-type

The cable shall conform to RG 6/U-type coaxial cable specifications.

9.1.1.2 Shielding

The cable assembly shall provide a transfer impedance through the shield(s) of less than 100-m Ω /m from DC through the Baudrate/2 equivalent frequency.

9.1.2 TV (video) cable plant specification

This subclause specifies a TV-style cable plant which is capable of communication at data rates specified in table 15. The cable plant is generally insensitive to data rate and therefore any installed portions of the cable plant may be used at any data rate.

Table 15 – TV-style cable plant

FC-0	Unit	100-TV-EL-S	50-TV-EL-S	25-TV-EL-S	12-TV-EL-S
Subclause		7.3	7.3	7.3	7.3
Attenuation (nom.) at Baudrate/2 equivalent frequency	dB/m	0,176	0,124	0,088	0,062
Connector Related Loss	dB/conn	0,25	0,25	0,25	0,25
Impedance	Ω	75	75	75	75
Impedance Tolerance	$\pm\Omega$	5	5	5	5

For those cables containing embedded equalization circuits, the operation of the cable may be both data rate and length specific. All cables containing such circuits shall be marked with in-

formation identifying the specific designed operational characteristics of the cable assembly.

9.1.2.1 TV-type

The cable shall conform to RG 59/U-type coaxial cable specifications.

9.1.2.2 Shielding

The cable assembly shall provide a transfer impedance through the shield(s) of less than 100-mΩ/m from DC through the Baudrate/2 equivalent frequency.

9.1.3 MI (miniature) cable plant specification

This subclause specifies a MI-style cable plant which is capable of communication at data rates specified in table 16. The cable plant is generally insensitive to data rate and therefore any installed portions of the cable plant may be used at any data rate.

Table 16 – MI-style cable plant

FC-0	Unit	100-MI-EL-S	50-MI-EL-S	25-MI-EL-S	12-MI-EL-S
Subclause		7.3	7.3	7.3	7.3
Attenuation (nom.) at Baudrate/2 equivalent frequency	dB/m	0,62	0,46	0,31	0,21
Connector Related Loss	dB/conn	0,25	0,25	0,25	0,25
Impedance	Ω	75	75	75	75
Impedance Tolerance	±Ω	5	5	5	5

9.1.3.1 MI-type

The cable shall conform to RG 179B/U type coaxial cable specifications.

9.1.3.2 Shielding

The cable assembly shall provide a transfer impedance through the shield(s) of less than 100-

mΩ/m from DC through the Baudrate/2 equivalent frequency.

9.1.4 Unbalanced cable interoperability

A specific goal of the unbalanced cable plant is to allow interoperability with restricted lengths of all styles of unbalanced cable. This requires that all cables be connector compatible. Such compatibility may be achieved with either special cables or adapters.

When unbalanced cable types are mixed, it is the users responsibility to validate that the lengths of cable used do not distort the signal beyond the received signal specifications in 7.3.

At transmission rates of 531 MBaud or greater, particular attention must be given to the transition between cable segments. No more than four connection points should be present from the ECL transmitter to the receiver of the data link.

9.2 Balanced cable plant

The balanced cables listed in this clause are not the only such cables that may be used to create such links. Usage of other cables are permitted to meet specific cost, performance, or other implementation specific criteria.

When using such cables it is the implementer's responsibility to insure that all impedance, attenuation (loss), jitter, skew, balance, and shielding are within the operating limits of the link type and data rate being implemented.

9.2.1 TP (shielded twisted pair) cable plant specification

This subclause specifies a TP-style cable plant which is capable of communication at data rates specified in table 17.

Because of the differential skew requirement, it is expected to be difficult to obtain cable of this type meeting all requirements of 100-TP-EL-S and 50-TP-EL-S. This cable may be used for distances shorter than the maximum length, providing that the differential skew at the end of the cable does not exceed the specified limit.

9.2.1.1 TP-type

The cable shall conform to IEC 1156-1. One cable contains two individually shielded twisted

Table 17 – TP-style cable plant

FC-0	Unit	100-TP-EL-S	50-TP-EL-S	25-TP-EL-S	12-TP-EL-S
Subclause		7.4 XRE F	7.4 XRE F	7.4 XRE F	7.4 XRE F
Attenuation (nom.) at Baudrate/2e quivalent frequency	dB/m	0,310	0,220	0,155	0,110
Connector Related Loss	dB/conn	0,25	0,25	0,25	0,25
Impedance	Ω	150	150	150	150
Impedance Tolerance	$\pm\Omega$	10	10	10	10
Differential Skew	ps	175	350	700	1400

pairs. Of these two pairs, one is used as the transmitting medium, with the other used as the receiving medium.

The shielded twisted pair cable, when used in full duplex links, shall be wired in a crossover fashion as shown in figure 37, with each pair being attached to the transmit contacts at one end of the cable and the receive contacts at the other end.

9.2.1.2 Shielding

The cable assembly shall provide a transfer impedance through the shield(s) of less than 100-m Ω /m from DC through the bit-rate fundamental frequency.

9.2.2 TW cable plant specification

This subclause specifies a TW-style cable plant which is capable of communication at data rates specified in table 18.

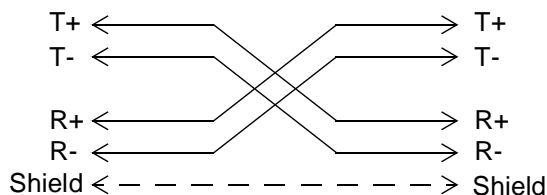

Figure 37 – Balanced cable wiring

Table 18 – TW-style cable plant

FC-0	Unit	100-TW-EL-S	50-TW-EL-S	25-TW-EL-S	12-TW-EL-S
Subclause		7.4	7.4	7.4	7.4
Attenuation (nom.) at Baudrate/2e quivalent frequency	dB/m	0,266	0,189	0,133	0,094
Connector Related Loss	dB/conn	0,25	0,25	0,25	0,25
Impedance	Ω	150	150	150	150
Impedance Tolerance	$\pm\Omega$	10	10	10	10
Differential Skew	ps	175	350	700	1400

For those cables containing embedded equalization circuits, the operation of the cable may be both data rate and length specific. All cables containing such circuits shall be marked with information identifying the specific designed operational characteristics of the cable assembly.

9.2.2.1 TW-type

The cable shall have a nominal differential impedance of 150 Ω . It shall consist of two parallel conductors, separated by a dielectric spacer, with an overall shield

TW-style cable may be used in either full duplex or simplex links. When configured in a full duplex link, the cable shall consist of two individually shielded balanced pairs in a common or joined outer insulating jacket, or two orthogonal balanced pairs with common shields and an overall insulating jacket. These two pairs shall be wired in a crossover fashion as shown in figure 37, with each pair being attached to the transmit contacts at one end of the cable and the receive contacts at the other end.

9.2.2.2 Shielding

The cable assembly shall provide a transfer impedance through the shield(s) of less than 100-m Ω /m from DC through the bit-rate fundamental frequency.

9.2.3 Balanced cable interoperability

A specific goal of the balanced cable plant is to allow interoperability with restricted lengths of all styles of balanced cable. This requires that all cables be connector compatible. Such compatibility may be achieved with either special cables or adapters.

When balanced cable types are mixed, it is the users responsibility to validate that the lengths of cable used do not distort the signal beyond the received signal specifications in 7.4

10 Optical interface connector specification

No enhancements from X3.230-1994 (FC-PH) or x3.xxx-1995 (FC-PH-2).

11 FC-1 8B/10B Transmission Code

No enhancements from X3.230-1994 (FC-PH) or x3.xxx-1995 (FC-PH-2).

12 FC-1 receiver and transmitter description

No enhancements from X3.230-1994 (FC-PH) or x3.xxx-1995 (FC-PH-2).

13 Loopback mode

No enhancements from X3.230-1994 (FC-PH) or x3.xxx-1995 (FC-PH-2).

14 Diagnostic mode

No enhancements from X3.230-1994 (FC-PH) or x3.xxx-1995 (FC-PH-2).

15 Transmitter safety

No enhancements from X3.230-1994 (FC-PH) or x3.xxx-1995 (FC-PH-2).

16 Ordered sets

No enhancements from X3.230-1994 (FC-PH) or x3.xxx-1995 (FC-PH-2).

17 Frame formats

No enhancements from X3.230-1994 (FC-PH) or x3.xxx-1995 (FC-PH-2).

18 Frame_Header

Enhancements to FC-PH and FC-PH-2 are specified.

18.3 Address identifiers

Additional values specified in FC-PH-3 are shown in table 33.

Hex value	Description
FFFFFF0 to FFFFFFF4	Reserved
FFFFFF5	Multicast Server (see 31.2.3)
FFFFFF6	Clock Synchronization Server (see FC-PH-3)
FFFFFF7	Security Key Distribution Server (see FC-GS-2)
FFFFFF8 to FFFFFFFF	Specified in FC-PH-2 Table 33

18.4 Data Structure (TYPE)

Additional values specified in FC-PH-3 are shown in table 36.

Encoded Value Wd 2, bits 31-24	Description
0000 0000 to 0010 1111	Specified in FC-PH Table 36
0011 0000 to 0011 0011	Specified in FC-PH-2 Table 36
0011 0100 to 0011 1111	Reserved
0100 0000 to 0100 0111	Specified in FC-PH Table 36
0100 1000 to 0100 1111	Reserved for FC-AE
0101 0000 to 0101 1111	Reserved
0110 0000 to 1111 1111	Specified in FC-PH Table 36

18.5 Frame Control (F_CTL)

The Frame Control (F_CTL) field (Word 2, Bits 23-0) is a three byte field that contains control information relating to the frame content. The following subclause describes the valid uses of F_CTL bits. If an error in bit usage is detected, a reject frame (P_RJT) shall be transmitted in response with an appropriate reason code (see 20.3.3.3) for Class 1 and 2. The format of the F_CTL field is defined in table 37.

Table 37 – (Page 1 of 2) - F_CTL field			
Control Field	Word 2, Bits	Description	Ref.
Exchange/Sequence Control			
Exchange Context	23	0 = Originator of Exchange 1 = Responder of Exchange	FC-PH
Sequence Context	22	0 = Originator of Sequence 1 = Responder of Sequence	FC-PH
First_Sequence	21	0 = Sequence other than first of Exchange 1 = First Sequence of Exchange	FC-PH
Last_Sequence	20	0 = Sequence other than last of Exchange 1 = Last Sequence of Exchange	FC-PH
End_Sequence	19	0 = Data frame other than last of Sequence 1 = Last Data frame of Sequence	FC-PH
End_Connection (Class 1) or Deactivate Class 4 circuit	18	0 = Originator of Exchange 1 = Responder of Exchange	FC-PH-2
Reserved	17		FC-PH-3
Sequence Initiative	16	0 = hold Sequence Initiative 1 = Transfer Sequence Initiative	FC-PH
X_ID reassigned	15	0 = X_ID assignment retained 1 = X_ID reassigned	FC-PH
Invalidate X_ID	14	0 = X_ID assignment retained 1 = Invalidate X_ID	FC-PH
ACK_Form	13-12	00 = No Assistance provided 01 = ACK_1 required 10 = ACK_N required 11 = ACK_0 required	FC-PH-2
Data Compression	11	0 = Uncompressed frame payload 1 = Compressed frame payload	FC-PH-2
Data Encryption	10	0 = Unencrypted frame payload 1 = Encrypted frame payload	FC-PH-3
Retransmitted Sequence	9	0 = Original Sequence transmission 1 = Sequence retransmission	FC-PH
Unidirectional Transmit (Class 1) or Remove Class 4 circuit (Class 4)	8	0 = Bidirectional transmission (Class 1) 1 = Unidirectional transmission (Class 1) 0 = Retain or deactivate circuit (Class 4) 1 = Remove circuit (Class 4)	FC-PH-2

Table 37 – (Page 2 of 2) - F_CTL field			
Control Field	Word 2, Bits	Description	Ref.
Continue Sequence Condition	7-6	Last Data Frame - Sequence Initiator 00 = No information 01 = Sequence to follow - immediately 01 = Sequence to follow - soon 01 = Sequence to follow - delayed	FC-PH
Abort Sequence Condition	5-4	ACK Frame - Sequence Recipient: 00 = Continue Sequence 01 = Abort Sequence, perform ABTS 10 = Stop Sequence 11 = Immediate Sequence retransmission requested Data frame (1st of Exchange) - Sequence Initiator: 00 = Abort, Discard multiple Sequences 01 = Abort, Discard a single Sequence 10 = Process policy with infinite buffers 11 = Discard multiple Sequences with immediate retransmission	FC-PH and FC-PH-3
Relative Offset present	3	0 = Parameter field not meaningful 1 = Parameter field - Relative Offset	FC-PH
Exchange reassembly	2	Reserved for Exchange reassembly	FC-PH
Fill Data Bytes	1-0	End of Data field - bytes of fill 00 = 0 bytes of fill 01 = 1 byte of fill (last byte of Data field) 10 = 2 bytes of fill (last 2 bytes of Data field) 11 = 3 bytes of fill (last 3 bytes of Data field)	FC-PH

• **Bit 10 - Data Encryption Status**

Data encryption status bit (F_CTL bit 10) is used by the Sequence Initiator to indicate to the Sequence Recipient that the Information Category to which the payload in the frame belongs is encrypted. The bit is meaningful in all Data frames of the Information Category to which the Data frames belong. The bit is not meaningful on ACK, BSY, or RJT frames.

- By resetting Data encryption status bit = 0, the Sequence Initiator is indicating that the payload in the frame belonging to the Information Category is not encrypted.
- By setting Data encrypted status bit = 1, the Sequence Initiator is indicating that the payload in the frame belonging to the Information Category is encrypted.

Table 36C – Data encryption status

Word 2, F_CTL Bit 10	
Encode	Meaning
0	Unencrypted frame Payload
1	Encrypted frame Payload

• **Bits 5-4 - Abort Sequence Condition**

The following details changes to “Process Policy with Infinite Buffers”.

The Abort Sequence Condition bits shall be set to a value by the Sequence Initiator on the first Data frame of an Exchange to indicate that the Originator is requiring a specific error policy for this Exchange. For Classes 1, 2, and 4, the Abort Sequence Condition bits shall not be meaningful on other Data frames within an Exchange. For Class 3 process policy support, the Abort Sequence Condition bits shall be set to 1 0 on each data frame with the sequence to indicate that the originator is requiring process policy to be used for the sequence. The error policy passed in the first frame of the sequence of the first Sequence of an Exchange shall be the error policy supported by both N_Ports participating in the Exchange. Additionally, for Class 3 operation the error policy passed in the

first received frame of the sequence shall be the error policy supported by both N_Ports participating in the Exchange (see 29.6.1.1)

- 0 0 = Abort, Discard multiple Sequences
- 0 1 = Abort, Discard a single Sequence
- 1 0 = Process policy with infinite buffers
- 1 1 = Discard multiple Sequences with immediate retransmission

In the Abort, Discard multiple Sequences Error Policy, the Sequence Recipient shall deliver Sequences to the FC-4 or upper level in the order transmitted under the condition that the previous Sequence, if any, was also deliverable. If a Sequence is determined to be non-deliverable, all subsequent Sequences shall be discarded until the ABTS protocol has been completed. The Abort, Discard multiple Sequences Error Policy shall be supported in Class 1, 2, 3, or 4.

In the Abort, Discard a single Sequence Error Policy, the Sequence Recipient may deliver Sequences to the FC-4 or upper level in the order that received Sequences are completed by the Sequence Recipient without regard to the deliverability of any previous Sequences. The Abort, Discard a single Sequence Error Policy shall be supported in Class 1, 2, 3, or 4.

In the Process policy with infinite buffers, frames shall be delivered to the FC-4 or upper level in the order transmitted. Process policy with infinite buffers shall only be allowed in Class 1 and Class 3. In Class 1, Process policy with infinite buffers shall use ACK_0 (see 20.3.2.2).

• **Bit 3- Relative Offset present**

When bit 3 is set to zero on a Data frame, the Parameter Field is not meaningful. That is, it may be set by the Sequence Initiator, but it shall be ignored by the Sequence Recipient. When bit 3 is set to one in a Data frame, the Parameter Field contains the Relative Offset for the Payload of the frame. Bit 3 is only meaningful on Data frames of a Sequence and shall be ignored on ACK and Link_Response

frames. Bit 3 is not meaningful on Basic Link_Data frames.

NOTE – When bit 3 is set to 0 on a Data frame, although the Sequence Recipient ignores the value in the Parameter Field, it may pass it to an upper level.

18.6 Sequence_ID (SEQ_ID)

18.7 DF_CTL

Data_Field Control (DF_CTL) is a one byte field (Word 3, bits 23-16) that specifies the presence of optional headers at the beginning of the Data_Field for Device_Data or Video_Data frames. DF_CTL bits are not meaningful on Link_Control or Basic Link Service frames. Control bit usage is shown in table 40.

Table 40 – DF_CTL bit definition	
Word 3, Bits(s)	Optional header
23	Reserved for Extended Frame_Header
22	Reclaimed from Expiration_Security_Header and Reserved
21	0 = No Network_Header 1 = Network_Header
20	0 = No Association_Header 1 = Association_Header
19-18	Reserved
17-16	0 0 = No Device_Header 0 1 = 16 byte Device_Header 1 0 = 32 byte Device_Header 1 1 = 64 byte Device_Header

The Optional Headers shall be positioned in the Data Field in the order specified with the bit 23 header as the first header in the Data Field, the bit 22 header as the second header in the Data Field, and so forth, in a left to right manner corresponding to bits 23, 22, 21, and so forth as shown in figure 47.

If either bit 17 or 16 is set to one, then a Device Header is present. The size of the Device Header is specified by the encoded value of bits 17 and 16 as shown.

If an Optional Header is not present as indicated by the appropriate bit in DF_CTL, no space shall be allocated for the Header in the Data

Field of the frame. Therefore, for example, if bits 23 and 22 are zero and bit 21 is one, the first data byte of the Data Field contains the first byte of the Network_Header.

See clause 19 for a discussion on Optional Headers.

18.9 Word 4, Bits 31-16

Word 4, Bits 31-16 shall identify the Exchange_ID assigned by the Originator of the Exchange and, if enabled, the Priority that may be used by the Fabric to establish connections for all classes of service.

When Priority is enabled, Word 4, Bits 31-24 shall specify the Priority and Word 4, Bits 23-16 shall specify the Originator Exchange_ID (OX_ID). When Priority is not enabled, Word 4, Bits 31-16 shall specify the Originator Exchange_ID (OX_ID). Priority is valid for all Classes of service except Class 3 and is enabled via Login (see 23.6.7.2). See table 160 and table 161 for illustrations of this field.

NOTE – When priority is enabled, the number of available Exchanges is reduced to 254.

Table 160 – Priority/Preemption enabled	
Bit(s)	Field
31	0 = No Preemption 1 = Preemption
30-24	Priority
23-16	OX_ID

Table 161 – Priority/Preemption not enabled	
Bit(s)	Field
31-16	OX_ID

18.9.1 Originator Exchange_ID (OX_ID)

The Originator Exchange_ID is a two byte field (Word 4, Bits 31-16) that shall identify the Exchange_ID assigned by the Originator of the Exchange and if enabled, the priority that may be used by the Fabric to establish connections for all classes of service and a preemption flag

to indicate that an **SOFc1** is a preemption request. If priority is enabled the priority shall be 7 bits (Word 4, Bits 30-24), the preemption request flag shall be 1 bit (Word 4, Bit 31), and the Exchange_ID shall be one byte (Word 4, Bits 23-16). If priority is not enabled the Exchange_ID shall be two bytes (Word 4, Bits 31-16).

Each Exchange shall be assigned an identifier unique to the Originator or Originator-Responder pair. If the Originator is enforcing uniqueness via the OX_ID mechanism, it shall assign a unique value for OX_ID other than hex 'FFFF' ('FF' if priority enabled) in the first Data frame of the first Sequence of an Exchange. An OX_ID of hex 'FFFF' ('FF') indicates that the OX_ID is unassigned and that the Originator is not enforcing uniqueness via the OX_ID mechanism. If an Originator uses the unassigned value of hex 'FFFF' ('FF') to identify the Exchange, it shall have only one Exchange (OX_ID= hex 'FFFF' ('FF')) with a given Responder.

An Originator Exchange Status Block associated with the OX_ID is used to track the progress of a series of Sequences which comprises an Exchange. See clause 24 for a discussion of Sequences and Exchanges. See 24.8.1 for a description of the Exchange Status Block.

NOTE – If hex 'FFFF' ('FF' if priority enabled) is used as the OX_ID throughout the Exchange, then the Originator uses an alternate Sequence tracking mechanism. If the OX_ID is unique, it may be used as an index into a control block structure which may be used in conjunction with other constructs to track frames.

18.9.2 Priority

If the Originator N_Port indicated during Login that Priority is supported, the following rules shall apply to the use of the Priority field:

NOTE – If the Originator N_Port indicated during Login that Priority is not supported, it cannot be used because the Priority field does not exist (it becomes an extension of the OX_ID field).

a) A value of hex '00' shall indicate that no Priority has been assigned to the frame. The remaining values shall indicate, in ascending order, the relative priority of the frame. That is, a Priority of hex '23' shall be considered to have a lower priority than a Priority of hex '57'. The Fabric may use the Priority to resolve resource contention or to determine the order in which to deliver frames.

b) In Class 1, Priority is meaningful for a dedicated connection. The Priority for a dedicated connection shall be established by the priority value provided by the SOFc1 frame.

NOTE – Changing Priority in a subsequent frame of a Dedicated Connection will not affect the Fabric. However, if the Responder N_Port does not support Priority and is using an RX_ID of hex 'FFFF', its ability to track the Exchange will be destroyed. This is because it is using the OX_ID to track the Exchange and it will consider all of Word 4, bits 31-16 to be the OX_ID.

c) In Class 2, Priority is meaningful for an Exchange. Priority shall be set by the Exchange Originator on the first frame of the Exchange. Priority shall be modified by the Exchange Originator only on an SOFi2 frame and under the following conditions:

- 1) The Responder has indicated during Login that it supports Priority, or the Responder has returned an RX_ID not equal to hex 'FFFF', or
- 2) The Responder has indicated during Login that it does not support Priority, the Responder has returned an RX_ID of hex 'FFFF', and the OX_ID has previously been invalidated.

NOTE – If the Responder is using an RX_ID not equal to hex 'FFFF', it is tracking the Exchange via the RX_ID and not the OX_ID. Therefore, modification of Word 1, Bits 31-16 will not affect it. Also, if the Responder supports Priority, it recognizes that the OX_ID is only Word 4, bits 23-16.

Priority shall only be modified by the Exchange Responder on an SOFi2 frame.

d) In Class 3, Priority shall not be used. That is, all of Word 4, bits 31-16 shall be considered the OX_ID.

e) In Class 4, Priority is meaningful for a virtual circuit. Priority shall be established by the priority value provided by the Quality of Service Request frame.

NOTE – Once a Virtual Circuit has been set up, Priority is meaningless.

19 Optional headers

This clause describes the changes that are made in FC-PH-3 to the FC-PH Optional headers.

19.1 Introduction

Optional headers are defined within the Data Field of a frame are:

- a) Reserved (reclaimed from Expiration_Security_Header)
- b) Network_Header
- c) Association_Header
- d) Device_Header

The presence of optional headers is defined by control bits in the DF_CTL field of the Frame_Header. The sequential order of the optional headers, Payload, and their sizes are indicated in figure 47.

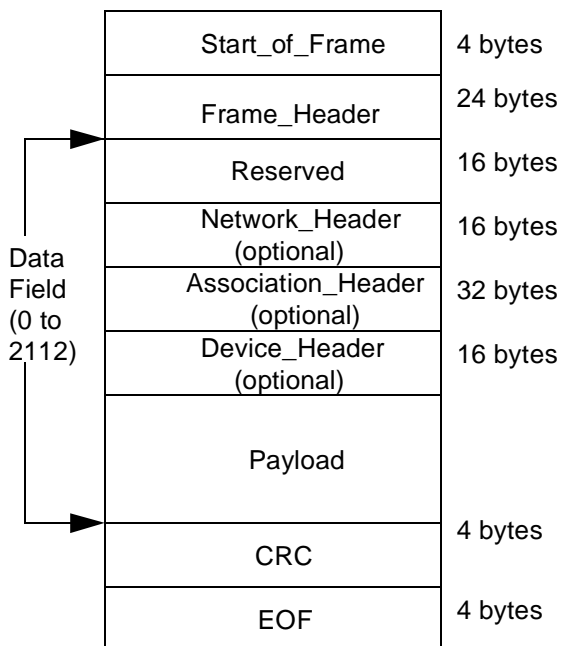

Figure 47 – Optional headers order

The first 16 bytes of the Data Field after the Frame_Header have been reclaimed from the Expiration_SecurityHeader and are reserved for future use. If present, a Network_Header shall be the next 16 bytes of the Data Field. If present, a Association_Header shall be the next 16 bytes of

the Data Field. If present, a Device_Header shall be the next 16 bytes of the Data Field. If none of the optional headers is present, no space in the Data Field shall be reserved.

19.2 Expiration_Security_Header

The Expiration_Security_Header defined in FC-PH is reclaimed and its space is reserved for future use.

19.3 Network_Header

This clause details the changes due to the reclamation of the CCITT NAA identifier.

NOTE – The CCITT NAAs are reclaimed due to the non-existence of a registration authority for these addresses.

NOTE – Although this clause is referenced by 23.6.4 and 23.6.5, it is important to note that the usage of the Network Header for network routing is very different than the use of the same *format* to define N_Port and node identification during Login. For example, the Network Header may change as other NAA types are defined, but this does not imply that these are valid for use as identifiers during Login. Furthermore, one format or even value may be used in the Network Header for routing and a different format or value may be used in the Login payload for identification.

19.3.1 D_NAA or S_NAA

Destination Network_Address_Authority (D_NAA) or Source Network_Address_Authority (S_NAA) field indicates the authority responsible for the administration of the network address (destination or source) used. The Network_Address_Authority indicators are shown in table 45.

Bits	NAA
63 62 61 60	
0 0 0 0	ignored
0 0 0 1	IEEE
0 0 1 0	IEEE extended
0 0 1 1	locally assigned
0 1 0 0	IP
0 1 0 1	Reserved
...	

1 0 1 1	Reserved
1 1 0 0	Reclaimed from CCITT
1 1 0 1	Reserved
1 1 1 0	Reclaimed from CCITT
1 1 1 1	Reserved

19.3.2.5 CCITT 60-bit address

This FC-PH clause is deleted.

19.4 Association Header

The following changes to the Association Header are indicated in figure 52 and table 45.

word	bits			
	31-24	23-16	15-8	7-0
0	Validity	Originator P_AS (most significant 3 bytes)		
1	Originator P_AS (least significant 4 bytes)			
2	Reserved	Responder P_AS (most significant 3 bytes)		
3	Responder P_AS (least significant 4 bytes)			
4	Originator O_AS (most significant 4 bytes)			
5	Originator O_AS (least significant 4 bytes)			
6	Responder O_AS (most significant 4 bytes)			
7	Responder O_AS (least significant 4 bytes)			

Figure 52 – Association_Header

Bit	Description	Ref
31	Originator P_AS 0 = not meaningful 1 = meaningful	FC-PH
30	Responder P_AS 0 = not meaningful 1 = meaningful	FC-PH
29	Originator O_AS 0 = not meaningful 1 = meaningful	FC-PH
28 0	Responder O_AS 0 = not meaningful 1 = meaningful	FC-PH
27 to 25	Reserved	FC-PH-3
24	Multicast P_AS 0 = Unicast 1 = Multicast	FC-PH-3

• Bit 56 - Multicast Process_Associator

This bit set to one shall indicate that the passed Process_Associator shall be processed as a multicast Process_Associator by the recipient N_Port. That is, the N_Port shall perform an internal multicasting of the payload of the received frame to all images within the Multicast Group specified by the Process_Associator. This bit set to zero shall indicate that the passed Process_Associator shall be processed as a unicast Process_Associator by the Recipient N_Port. That is, the N_Port shall pass the payload of the received frame to the image specified by the Process_Associator. See X3.xxx-1995 (FC-PH-2), clause 31 for a description of Multicast support.

20 Data frames and responses

FC-PH-3 enhancements to Data frames and responses defined in FC-PH and FC-PH-2 are specified.

20.3 Link_Control

A Link_Response frame (F_RJT) shall be sent by the Fabric in reply to a Class 1 preemption request frame if the fabric rejects the request, or preemption is not enabled. To reject the preemption request the fabric shall send an F_RJT link response frame with a "Preemption Request Rejected" or "Preemption Not Enabled" reason code.

20.3.3.2 N_Port Busy (P_BSY)

Table 53 provides the enhanced Busy reason codes based on FC-PH and FC-PH-2 table 53.

Word 5, bits 23-16	Description
0000 0001	Specified in FC-PH table 53
0000 0011	Specified in FC-PH table 53
0000 0111	Partial Multicast Busy (see Clause 31)
1111 1111	Specified in FC-PH table 53
Others	Reserved

20.3.3.3 Reject (P_RJT, F_RJT)

Table 55 provides the enhanced Reject reason codes based on FC-PH and FC-PH-2 table 55.

Word 0, bits 27-24	Description	By
0000 0001 to 0001 0100	Specified in FC-PH table 55	
0001 0101	Specified in FC-PH-2 table 55	
0001 0110 to 0001 1010	Specified in FC-PH table 55	
0001 1011 to 0001 1111	Specified in FC-PH-2 table 55	
0010 0000	Preemption Request Rejected (see clause 28.9)	F
0010 0001	Preemption Not Enabled (see clause 23)	F
0010 0010	Multicast Error (see clause 31)	F
0010 0011	Multicast Error terminate (see clause 31)	F
Others	Reserved	

NOTE – The "By" column indicates that this Reason Code is set by the fabric (F) , N_Port (N), or both (B).

21 Link Services

This clause describes the changes that are made in FC-PH-3 for:

- E_D_TOV timer resolution enhancement.
- Default login values.
- Basic link service commands
- Extended link services.
- Report Node Capabilities information.

21.1.1 Default Login values

Prior to Login or following Logout, a default set of Service Parameters apply:

- Concurrent Sequences = 1,
- Total Concurrent Sequences = 1,
- End-to-end Credit = 1,
- Buffer-to-buffer Credit = 1,

- Receive_Data_Field Size = 128,
- X_ID interlock required,
- no X_ID reassignment,
- ACK_1,
- Discard multiple Sequences Error Policy,
- Relative Offset not used,
- E_D_TOV Resolution = 0,
- Other optionally supported features shall not be used or required.

Following Login with the destination, an N_Port shall use the Service Parameters obtained through Login.

21.2 Basic Link Service commands

Enhancements to FC-PH and FC-PH-2 is specified in table 57.

Table 57 – Basic Link Service Commands						
Word 0		Word 1	Word 5	Description	Abbr.	Ref.
Routing (bits 31-28)	Category (bits 27-24)	Type (bits 31-24)	Parameter			
Basic Link Service						
1000	0000	0000 0000	N/A	No Operation	NOP	Specified in FC-PH table 57
	0001			Abort Sequence	ABTS	
	0010			Remove Connection	RMC	
	0011			Reserved		
	0100			Basic Accept	BA_ACC	Specified in FC-PH-3
	0101			Basic Reject	BA_RJT	
	0110			Preempted	PRMT	
	Others					Reserved

21.2.7 Dedicated Connection Preempted (PRMT)

The PRMT basic link service command shall indicate that the connection for which this N_Port is participating has been preempted and no longer exists. All sequences associated with this connection have ended abnormally.

Protocol:

Connection Preempted Notification
No Reply frame

Format: FT_1

Addressing: The D_ID field shall designate the N_Port to which this basic link service command is directed by the Fabric. The S_ID field shall be equal to the S_ID field in the **SOFC1** preemption request frame which triggered this preemption notification.

OX_ID: If priority is enabled (see clause 18 and 23) the upper byte of the OX_ID field shall be equal to the upper byte of the OX_ID field in the **SOFC1** preemption request frame which triggered this preemption notification.

Payload: None

Reply Sequence: None

21.3 Extended Link Services

Table 61 summarizes FC-PH,FC-PH-2, and FC-PH-3 Extended Link Service Requests and Replies.

Table 61 – Extended Link Service Commands						
Word 0		Type	Payload	Description	Abbr.	Ref.
Routing (bits 31-28)	Category (bits 27-24)		Word 0 (bits 31-24)			
Extended Link Service Request						
0010	0010	0000 0001	hex '03'	N_Port Login	PLOGI	Specified in FC-PH 21.4 and table 61
			hex '04'	F_Port Login	FLOGI	
			hex '05'	Logout	LOGO	
			hex '06'	Abort Exchange	ABTX	
			hex '07'	Read Connection Status	RSC	
			hex '08'	Read Exchange Status Block	RES	
			hex '09'	Read Sequence Status Block	RSS	
			hex '0A'	Request Sequence Initiative	RSI	
			hex '0B'	Establish Streaming	ESTS	
			hex '0C'	Estimate Credit	ESTC	
			hex '0D'	Advise Credit	ADVC	
			hex '0E'	Read Time-out Value	RTV	
		hex '0F'	Read Link Status	RLS	Specified in FC-PH 21.4 and table 61	
		hex '10'	Echo	ECHO		
hex '11'	Test	TEST				
			hex '12'	Reinstate Recovery Qualifier	RRQ	

Table 61 – Extended Link Service Commands						
Word 0		Type	Payload	Description	Abbr.	Ref.
Routing (bits 31-28)	Category (bits 27-24)		Word 0 (bits 31-24)			
Extended Link Service Request						
0010	0010	0000 0001	hex '20'	Process Login	PRLI	Specified in FC-PH-2 table 61
			hex '21'	Process Logout	PRLO	
			hex '22'	State Change Notification	SCN	
			hex '23'	Test Process Login State	TPLS	
			hex '24'	Third Party Process Logout	TPRLO	
			hex '30'	Get Alias_ID	GAID	
			hex '31'	Fabric Activate Alias_ID	FACT	
			hex '32'	Fabric Deactivate Alias_ID	FDACT	
			hex '33'	N_Port Activate Alias_ID	NACT	
			hex '34'	N_Port Deactivate Alias_ID	NDACT	
			hex '40'	Quality of Service Request	QoSR	
			hex '41'	Read Virtual Circuit Status	RVCS	
			hex '50'	Discover N_Port Service Parm	PDISC	
			hex '51'	Discover F_Port Service Parm	FDISC	
			hex '52'	Discover Address	ADISC	
	hex '53'	Report Node Capability	RNC	FC-PH-3		
	Others	Reserved				
Extended Link Service Reply						
0010	0011	0000 0001	hex '01'	Link Service Reject	LS_RJT	Specified in FC-PH 21.4 and table 61
			hex '02'	Accept	ACC	
			Others	Reserved		

21.4 Extended Link Service requests

This section contains modifications to Extended Link Service requests defined in X3.230-1994 (FC-PH) and X3.297-1996 (FC-PH-2), along with the definition of additional Extended Link Services.

21.4.13 Read Timeout Value (RTV)

The RTV Link Service request Sequence requests an N_Port or F_Port (hex 'FFFFFFE') to return the Resource_Allocation_Timeout Value (R_A_TOV) and the Error_Detect_Timeout Value (E_D_TOV) in the Accept reply Sequence. This provides the N_Port transmitting the request with the information regarding these values from another N_Port or from the F_Port. Usage of E_D_TOV and R_A_TOV is discussed in X3.230-1994 (FC-PH) 29.2.1.

Protocol:

Read Timeout Value (RTV) request Sequence

Accept (ACC) reply Sequence

Format: FT_1

Addressing: The S_ID field designates the source N_Port requesting the timeout interval values. The D_ID field designates the destination N_Port or F_Port to which the request is being made.

Payload: The format of the Payload is shown in table 162.

Item	Size - Bytes
hex '0E000000'	4

Reply Link Service Sequence:

Service Reject (LS_RJT)

signifies rejection of the RTV command (see X3.230-1994 (FC-PH) 21.5.2)

Accept

signifies that the N_Port or F_Port has transmitted the requested data.

– Accept Payload:

The format of the Accept Payload is shown in table 162. Timeout values are specified as a count of either 1 ms or 1 ns increments, depending on the setting of Bit 26 in the Timeout Qualifier.

Item	Size - Bytes
hex '02000000'	4
Resource_Allocation_Timeout Value (R_A_TOV) (see 29.2.1)	4
Error_Detect_Timeout Value (E_D_TOV) (see 29.2.1)	4
Timeout Qualifier (see 23.6.3.7)	4

R_A_TOV: In a point-to-point topology, this value shall have the same resolution as E_D_TOV, as indicated by the Timeout Qualifier.

NOTE – In a point-to-point topology, R_A_TOV must be twice E_D_TOV, which means it must have the same resolution. In other topologies, R_A_TOV will always be in 1 ms increments.

Timeout Qualifier:

Bits 31-27: Reserved

Bit 26: E_D_TOV Resolution

If Bit 26 is zero, the value specified in the E_D_TOV field shall indicate a count of 1 ms increments. If Bit 26 is one, the value specified in the E_D_TOV field shall indicate a count of 1 ns increments.

Bits 25-0: Reserved

21.5 Extended Link Service reply Sequences

21.5.2 Link Service Reject (LS_RJT)

Table 91 summarizes FC-PH,FC-PH-2, and FC-PH-3 LS_RJT reason codes.

Table 91 – LS_RJT reason code explanation		
Encoded Value (Bits 15-8)	Description	Applicable Commands
hex '00'	No additional explanation	ABTX, ADVC, ESTS, FLOGI, PLOGI, LOGO, RCS, RES, RLS, RSS, RTV, RSI, PRLI, PRLO, TPLS, TPRLO, GAID, FACT, FDACT, NACT, NDACT, QoS, RVCS, PDISC, FDISC, ADISC, RNC
hex '01' to hex '2B'	See FC-PH Table 91	See FC-PH Table 91
hex '2C'	Request not supported	ADVC, ESTS, ESTC, PRLI, PRLO, TPLS, TPRLO, GAID, FACT, FDACT, NACT, NDACT, QoS, RVCS, PDISC, FDISC, ADISC, RNC
hex '2D'	Invalid Payload Length	FLOGI, PLOGI
hex '30' to hex '38'x	See FC-PH-2 Table 91	See FC-PH-2 Table 91
hex '40' to hex '42'x	See FC-PH-2 Table 91	See FC-PH-2 Table 91

21.20 Report Node Capabilities Information (RNC)

The RNC Link Service request Sequence provides for the exchange of vendor identification, node capabilities, and other vendor unique information. This link service may be used to query an N_Port to discover what document identifiers (and the associated FC-4 protocols and profiles) it supports. Optionally RNC may be used between two N_Ports to specify which specific document(s) should be used to set operating parameters for these two N_Ports. RNC may also be used to specify options or additional parameters specified by the referenced documents which are not specified during N_Port Login.

The RNC Link Service may be used anytime after N_Port Login.

Protocol:

Report Node Capabilities Information (RNC) request Sequence

Accept (ACC) reply Sequence

Format: FT_1

Addressing: The S_ID field designates the source N_Port requesting the capabilities information. The D_ID field designates the destination N_Port to which the request is being made.

Payload: The format of the Payload is shown in table 164.

Table 164 – RNC/ACC Payload	
Item	Size - Bytes
hex '53' for RNC hex '02' for ACC	1
Reserved	1
Payload Length	2
RNC Flags	1
Reserved	2
VU Information Length (VU_Len)	1
Vendor Identifier	8
Capability Entry(s)	M
Vendor Unique Information	0-128

Payload Length: Bytes 2-3 of Word 0 contain a 16-bit unsigned binary integer that specifies the length of the RNC payload.

The minimum length of an RNC or RNC Accept payload is 16 bytes. The maximum length shall be limited to 256 bytes. The requesting N_Port shall be responsible for ensuring payload length does not exceed this limit. The maximum length of the RNC Accept payload is not specified.

RNC Flags: Byte 0 of Word 1 contains an 8-bit flag field which defines options applicable to all Capability Entries in the RNC payload.

- **Bit 7: Select (S)**

0 = Report all capabilities

1 = Select option requested

If the Select bit is zero, the RNC Accept payload shall contain all Capability Entries the responding N_Port wishes to report.

If the Select bit is set to 1, the requesting N_Port is specifying that the RNC Accept payload contain only one Capability Entry. The Capability Entry specified in the Accept payload shall be selected from the list of capabilities given in the RNC payload. The Select bit also specifies that the Low Revision and High Revision fields in the RNC Accept payload shall be equal for the capability being selected. If the responding node does not support any of

the capabilities listed, it shall return n RNC Accept without any Capability Entries.

The act of selecting a specific capability entry allows two nodes to agree upon a set of specific operating parameters. The selection may set or imply certain operating modes or parameters for a particular protocol, FC-4, or other Fibre Channel characteristic as defined by the document referenced in the capability entry. For example, if the capability entry refers to a profile for a specific FCP implementation, then selecting that capability entry may specify class, process login parameters, allowable SCSI commands, etc.

The RNC link service shall not replace the normal parameter exchange (such as process login). It does, however, provide a mechanism for both nodes to anticipate the preferred parameters of the other node.

If two N_Ports support multiple FC-4s, protocols, or for some other reason require a selection of more than one capability entry, the RNC link service may be used multiple times. (See Invalidate Previous bit below).

- **Bits 6-0: Reserved (r)**

VU Information Length (VU_Len): Byte 3 of word 1 contains an 8-bit unsigned binary integer that specifies the length of the Vendor Unique Information field in bytes. Up to 128 bytes are supported.

Vendor Identifier: The Vendor Identifier field contains eight bytes of ASCII data (code values hex '20' through hex '7E') identifying the vendor of the product. The data shall be left aligned within this field. Any unused bytes are placed at the end of the field (highest offset) and the unused bytes shall be filled with space characters (hex '20'). See X3T10/995D (SCSI-3 Primary Commands) Annex C for an example of this formatting.

NOTE – It is intended that this field provide a unique vendor identification of the manufacturer of the Fibre Channel device. In the absence of a formal registration procedure, X3T10 maintains a list of vendor identification codes in use. Vendors are

requested to voluntarily submit their identification codes to X3T10 to prevent duplication of codes.

Capability Entry: The Capability Entry field is shown in table 165.

Table 165 – Capability Entry	
Item	Size - Bytes
Flags: 'IEVVrrPP' (bits)	1
Document Identifier	1
Low Revision	1
High Revision	1
Reserved	0 or 2
Extension Length (N)	0 or 2
Extension	0 or N

Flags: The Flags specify the type of entry as well as other defining information for this entry.

- **Bit 7 - Invalidate Previous (I)**

0 = Selectable Entry

1 = Invalidate Previous Selection

This bit is only meaningful if the RNC Flags Select bit is on. Furthermore, it shall be set on the first Capability Entry in the payload. It is used when the requesting N_Port wants to cancel the capability entry selected with a previous RNC link service request and have the responding N_Port make a new selection.

When the RNC Flags Select bit is set to 1, and the first Capability Entry Flags Invalidate bit is set to 0, then the requesting N_Port is specifying that the responding N_Port shall select one of the Capability Entries from the entries in the payload.

When the RNC Flags Select bit is set to 1 and the Invalidate bit is set to 1 in the first Capability Entry, then the requesting N_Port is indicating that this capability entry shall be invalidated. All bytes in the Capability Entry marked with the Invalidate bit shall match the values of a Capability Entry selected during a previous RNC link

service exchange. The responding N_Port shall clear any parameter or mode settings associated with the invalidated Capability Entry. The responding N_Port shall select another Capability Entry from the set of entries in the RNC payload. (The Capability Entry with the Invalid bit set is not a valid selection).

- **Bit 6 - Extended (E)**

0 = No Extension

1 = Extended Format

If the Extended bit is 0, then the Capabilities Entry is exactly 4 bytes long.

If the Extended bit is 1, then the Capabilities Entry is greater than 4 bytes long. Byte 6 (offset from the beginning of this capability entry) specifies the Extension Length.

- **Bits 5-4 - Vendor Unique (V)**

00 = Document Identifier is not vendor unique.

01 = Document Identifier is vendor unique

10 = Document Identifier is vendor unique as defined by vendor of the N_Port receiving the payload.

11 = reserved

Vendor unique Document Identifiers are qualified by the 8-byte ASCII Vendor Identifier. Thus each vendor may use any identifier value, 0 through hex 'FF', for vendor unique document identifiers.

When the Vendor Unique bits are set to '10' the N_Port sending the RNC or RNC Accept must have previously obtained the Vendor Identifier of the destination N_Port. This is inherent if sending an RNC Accept. If sending an RNC then the information may have been obtained from a previous RNC/RNC Accept exchange or some other method outside the scope of this standard.

- **Bits 3-2 - Reserved (r)**

- **Bits 1-0 - Preference (P)**

Preference is a two bit value indicating

the level of support or performance relative to the other capabilities supported for this FC-4. These may be used as an aid in choosing a specific capability if multiple capabilities are supported. The Preference value ranges from 0 to 3.

00 = Best

01

10

11 = Worst

Document Identifier: If the V flags are 00 this is a document Identifier as specified in table 166. If the V flag is not '00' then this is a vendor unique Document Identifier.

Low Revision: The Low Revision field represents the lowest revision of the specified document supported.

High Revision: The High Revision field represents the highest revision of the specified document supported.

The revision fields shall represent a decimal revision between 0.0 (hex '00') and 25.5 (hex 'FF'). Changes to the revision number in increments smaller than 0.1 can not be represented by RNC.

Extension Length: The Extension Length is a 16-bit unsigned binary integer that specifies the number of additional bytes, including itself and the preceding reserved field, present in the extended capability entry.

The value of the Extension Length field shall be a multiple of four. Each document which defines extensions shall ensure the length of the extension allows four byte alignment.

NOTE – For example, if the extension is 1 bytes, the Extension Length is 8: 2 bytes for the reserved field, 2 bytes for the Extension Length field, and 4 bytes allocated for the Extension, of which only 1 is used.

Extension: Capability Entry extensions may be used to specify additional bit flags, parameters,

or other information as defined by the referenced document. This standard does not define the meaning or content of the extension beyond the Extension Length field.

Table 166 – Document Identifiers	
Profile or Standard Name	Identifier
Reserved	00
FC-LE	01
FC-SB	02
IPI-3	03
SCSI-FCP	04
FC-FP	05
Reserved	06-0F
FC-GS	10
FC-FG	11
FC-SW	12
FC-AL	13
Reserved	14-1F
IBM/HP/Ancor Deviations	FC-PH 4.2 20
FCSI Mixed Mode SCSI Profile	21
FCSI Class 2 SCSI Profile	22
FCSI IP Profile	23
FCSI IP Class 2 Profile	24
FC-PLDA - Private Loop Direct Attach	25
FLA -Fabric Loop Attach Profile	26
Reserved	27-FF

Vendor Unique Information: The format of the Vendor Unique Information is defined by vendor or profile specific documentation.

Reply Link Service Sequence:

Service Reject (LS_RJT)

signifies rejection of the RNC command (see 21.5.2)

Accept

signifies that the destination N_Port has transmitted the requested data.

- Accept Payload:

The format of the Accept Payload is identical to the format of the RNC payload, except for the command code, and is shown in table 164.

RNC Collision:

If an N_Port has transmitted an RNC Link Service request Sequence to an N_Port and receives an RNC Link Service request Sequence from the same N_Port before the RNC Accept Sequence then a collision has occurred. To avoid ambiguity in the case the Select option was used, N_Ports which implement RNC shall detect RNC collisions. In the case of a collision the N_Port shall compare N_Port_Names. If the N_Port_Name of the sequence recipient is less than the N_Port_Name of the sequence initiator, then the sequence recipient shall reply with an LS_RJT, Reason Code = "Logical busy".

22 Classes of Service

Enhancements to FC-PH and FC-PH2.

22.6 Class 6 - Uni-Directional Dedicated Connection

Class 6 is a service which provides Dedicated Connections for Reliable multicast (see clause 31) for a Fabric topology. A class 6 connection is requested by an N_Port for one or more destination N_Ports. An acknowledgement is returned by the destination N_Ports to a multicast server which returns an acknowledge to the connection initiator, establishing a reliable multicast connection. In general, once a connection is established, it shall be retained and guaranteed by the Fabric until the connection initiator requests removal.

22.6.1 Class 6 function

A Class 6 connection is requested by an N_Port to one or more destination N_Ports via transmission of a frame containing a **SOFc1**. A Class 6 **SOFc1** is identical to a Class 1 **SOFc1**. The Fabric recognizes the multicast D_ID and performs the Class 6 multicast function. The Fabric establishes circuits between the requesting N_Port and the destination N_Ports. The destination N_Ports each transmit an ACK, indicating acceptance, which are intercepted by the multicast server. The multicast server, based on the ACKs, RJTs, or BSYs received from the destinations, transmits an ACK, a P_RJT, or a P_BSY to the requesting N_Port indicating acceptance, rejection, or busy for the request. The return of an ACK indicates the establishment of a multicast connection. The Fabric retains the allocated circuits between the requesting N_Port and the destination N_Ports until the connection initiator request the Dedicated Connection be removed.

Class 1 Delimiters, as specified in FC-PH clause 22.1.3, are used to establish and remove the Dedicated Connection and to initiate and terminate one or more sequences within the Dedicated Connection.

Class 1 service parameters, as specified during Login, shall be used to manage Class 6 connections.

22.6.2 Class 6 rules

The following rules apply to exclusive Class 6 Connections. See FC-PH 22.4 for additional rules applicable to intermix. To provide a Class 6 Connection, the transmitting and receiving N_Ports, Fabric, and multicast server shall obey the following rules:

- a) Except for some Link Service Protocols (see FC-PH clause 21), an N_Port requesting a Class 6 Connection is required to have previously logged in with the Fabric and the N_Ports with which it intends to communicate, either implicitly or explicitly. To Login explicitly, the requesting N_Port shall use Fabric and N_Port Login protocols (see FC-PH clause 23).
- b) The Fabric is responsible for establishing a Connection at the request of an N_Port and retaining it until the requesting N_Port explicitly requests removal of the Connection or the requesting N_Ports link participates in a primitive sequence protocol (see FC-PH clause 16.4). To establish or remove the Dedicated Connection, the requesting N_Port shall use the Class 1 Delimiters as specified in FC-PH clause 22.1.3.
- c) After transmitting a Class 6/**SOFc1** frame, the N_Port requesting the Connection shall not transmit additional frames to the destination N_Ports until it receives, from the multicast server, an ACK which shall establish the connection.
- d) Once a Connection is established between multiple N_Ports, only the requesting N_Port (Connection Initiator) shall send data frames. Only the Connection Initiator shall cause the connection to be terminated. All frames shall contain S_ID and D_ID as appropriate (i.e. The D_ID shall be the multicast address).
- e) A destination N_Port shall acknowledge delivery of every valid Data frame with an ACK_1 or ACK_N, or the entire Sequence with a single ACK_0 (see FC-PH clause 22.1.5).
- f) The Sequence Initiator shall increment the SEQ_CNT field of each successive frame transmitted within a Sequence. The Fabric shall guarantee delivery of the frames at the

receivers in the same order of transmission within the Sequence (see FC-PH clause 24.3.6).

g) The Connection Initiator N_Port of an established Connection may originate multiple Exchanges and initiate multiple Sequences within that Connection. This N_Port shall assign a unique X_ID called OX_ID. The multicast server for the Exchange shall assign an X_ID unique to the Responders called RX_ID. The value of the RX_ID shall be negotiated during N_Port/Fabric login (see 23.6.8). Thus, within a given Connection, the value of OX_ID or RX_ID is unique to the respective N_Port and multicast server. The Sequence Initiator (Connection Initiator) shall assign a SEQ_Qualifier, for each Sequence it initiates, which is unique to the Sequence Initiator and the respective Sequence Recipients.

h) Communicating N_Ports and the multicast server shall be responsible for end-to-end flow control, without any fabric involvement. ACK frames are used to perform end-to-end flow control (see clause 22.1.5). All Class 6 frames, except Class 6/SOFc1, participate only in end-to-end flow control. A Class 6/SOFc1 frame participates in both end-to-end and buffer-to-buffer flow controls.

i) The Fabric may reject a request for a Class 6 Connection or issue a busy with a valid reason code. After the Dedicated Connection is established, the Fabric shall not interfere with the Connection. The Fabric shall issue a F_BSY to any Class 2 frame or discard any Class 3 frame, transmitted from a third N_Port and destined to one of the N_Ports engaged in the Connection (see FC-PH clauses 20.3.3.1 and 20.3.3.3).

j) The destination N_Ports specified in the Class 6/SOFc1 frame may respond with a busy or a reject with a valid reason code to this frame. The multicast server shall interpret these responses and respond with an ACK, busy, or a reject with a valid reason code to the requesting N_Port (see section on multicast server). Once the Dedicated Connection is established, the destination N_Ports shall not issue a busy but may issue a reject (see FC-PH clauses 20.3.3.2 and 20.3.3.3).

k) The End-to-end Credit established during the Login protocol by interchanging service Parameters shall be honored (see FC-PH clause 26.3). End-to-end credit shall be managed between Connection Initiator and the multicast server. At the beginning of a Connection, the End-to-end Credit_Count is reinitialized to the value determined during Login. A Class 6/SOFc1 frame shall share the End-to-end Credit with Class 2 frames (see FC-PH clause 26.3).

l) The Fabric shall guarantee full bandwidth availability to the connected N_Ports (see FC-PH clause 3 and annex M).

m) Frames within a Sequence are tracked on an Sequence_Qualifier and SEQ_CNT basis (see FC-PH clause 18.1.1)

n) Same as FC-PH Clause 22.1.2 item n.

o) If an N_Port does not support Class 6 (i.e. does not support Class 1) and receives a Class 6/SOFc1 frame, the N_Port shall issue a P_RJT with a SOFn1 and EOFdt with a reason code of Class not supported. If an F_Port does not support Class 6 and receives a Class 6/SOFc1 frame, the F_Port shall issue an F_RJT with a SOFn1 and EOFdt with a reason code of Class not supported.

p) Same as FC-PH Clause 22.1.2 item p.

q) The Connection Initiator shall send two zero length payload frames as the last two frames of a Sequence.

NOTE – This simplifies the processing of an abort on the last non-zero payload frame of a Sequence.

r) The effect of preemption of one destination N_Port on the remaining N_Ports is implementation-dependent.

22.6.3 Class 6 delimiters

Same as FC-PH Clause 22.1.3.

22.6.4 Class 6 frame size

Same as FC-PH Clause 22.1.4.

22.6.5 Class 6 flow control

ACK frames are used to perform Class 6 end-to-end flow control. ACK frames are started with SOFn1. Destination N_Ports shall not ter-

dpANS X3.xxx-199x

minate Sequences or Connections. All ACK frames shall end with **EOFn**.

All Class 6 frames shall follow end-to-end flow control rules (see FC-PH clause 26.4.1). The Class 6/**SOFC1** frame shall follow both end-to-end and buffer-to-buffer flow control rules (see FC-PH clause 26.5.1).

22.6.6 Stacked Connect-requests

Same as FC-PH Clause 22.1.6.

23 Login and Service Parameters

This clause describes the changes that are made in FC-PH-3 to support:

- the E_D_TOV timer resolution enhancement.
- Priority/Preemption
- Enhancements to FLOGI to expand the payload.

23.1 Introduction

The Login procedure is a method by which an N_Port establishes its operating environment with a Fabric, if present, and other destination N_Ports with which it communicates. Fabric Login and destination N_Port Login are both accomplished with a similar procedure using different Destination_Identifiers (D_IDs) and possibly different Source_Identifiers (S_IDs).

Login between an N_Port and the Fabric or between two N_Ports is long-lived. The number of concurrent N_Ports with which an N_Port may be logged in with is a function of the N_Port facilities available. There is no one to one relationship between Login and Class 1 Dedicated Connections.

Explicit Login is accomplished using the Login (FLOGI/PLOGI) Link Service Sequence within a separate Exchange to transfer the Service Parameters (contained in the Payload) of the N_Port originating the Login Exchange. The Accept (ACC) contains the Service Parameters of the Responder (contained in the Payload).

Implicit Login is a method of defining and specifying the Service Parameters of destination N_Ports by means other than the explicit use of the Login Exchange. Specific methods of **implicit** Login are not defined in FC-PH.

When Login is referred to throughout other sections of this document, either the **explicit** or **implicit** procedure is acceptable. Implicit Login is assumed to provide the same functionality as Explicit Login. Default Login values are specified in 21.1.1. Explicit Login replaces previous Service Parameters and initializes end-to-end or buffer-to-buffer credit, or both. The Login procedure shall follow the Exchange and Sequence management rules as specified in clause 24. Frames within a Sequence shall op-

erate according to R_RDY Primitive, ACK, and Link_Response rules specified in clause 20.

Explicit Fabric Login is performed during the initialization process under the assumption that a Fabric is present. The first explicit Login is directed to the Fabric using the well-known Fabric address (i.e., F_Port at hex 'FFFFFFE'). It is mandatory for all Fabric types to support the explicit Login procedure. In its first attempt at explicit Fabric Login, an N_Port shall set the following S_ID:

- Bits 23-0 equal to binary zeroes (denoted as 0), or
- Bits 23-8 equal to binary zeroes and bits 7-0 equal to a model-dependent value (denoted as 0000yy).

If the N_Port receives an F_RJT with a reason code of Invalid S_ID, it may use its last known native address identifier in the FLOGI Sequence as its S_ID.

The remainder of 23.1 is unchanged from FC-PH.

23.2 Applicability

No change from FC-PH.

23.3 Fabric Login

23.3.1 Explicit Fabric Login

The explicit Fabric Login procedure shall require transmission of a Login (FLOGI) Link Service Sequence within an Exchange with an assigned OX_ID by an N_Port with a Destination Identifier (D_ID) of the well-known F_Port address (FFFFFFE) and a Source Identifier (S_ID) of either 0 or 0000yy.

When S_ID = 0 is used, the F_Port shall either:

- assign a Fabric unique N_Port Identifier to the N_Port in the ACC reply Sequence, or
- return an F_RJT with a reason code indicating Invalid S_ID, if the Fabric does not support N_Port Identifier assignment. The N_Port shall assign its native N_Port Identifier by another method not defined in FC-PH and retry the FLOGI Sequence with an S_ID = X.

When S_ID = 0000yy is used, the F_Port shall either:

- assign a Fabric unique N_Port Identifier to the N_Port in the ACC reply Sequence by setting bits 23-8 and validating bits 7-0, or
- return an F_RJT with a reason code indicating Invalid S_ID, if the value in bits 7-0 does not allow a Fabric unique Identifier to be generated. The N_Port shall assign a different value for yy and retry the FLOGI Sequence with an S_ID = X.

If S_ID = X is used, the F_Port shall either:

- return an ACC reply Sequence with D_ID = X (confirming identifier), or
- return an F_RJT with a reason code indicating Invalid S_ID, if X is invalid.

If the F_Port has rejected both S_ID = 0 or 0000yy and S_ID = X, the N_Port shall attempt to reLogin with another value of X, or determine a valid value of X by a method not defined in FC-PH.

The remainder of 23.3.1 is unchanged from FC-PH.

23.3.2 Responses to Fabric Login

23.3.2.1 FLOGI with S_ID = 0 or 0000yy

Table 94 describes the set of possible responses to Fabric Login with an S_ID = 0 or 0000yy and a D_ID of hex 'FFFFFFE'. Further description of the response primitive or frame is found in clause 20.

Response/ Reply Seq	D_ID	S_ID	Indication	N_Port Action
1. R_RDY	N/A	N/A	<ul style="list-style-type: none"> - Class 1 (SOFc1) - Class 2 or 3 - successful frame delivery to F_Port or N_Port 	<ul style="list-style-type: none"> - wait for frame
2. Last ACK	0 or 0000yy	FFFFFFE	<ul style="list-style-type: none"> - FLOGI Sequence has been received by N_Port or F_Port 	<ul style="list-style-type: none"> - wait for Reply Data frame Sequence
3. ACC	X or XXXXyy	FFFFFFE	<ul style="list-style-type: none"> - OX_ID = FLOGI OX_ID - If Common Serv = F_Port, Fabric Login complete 	<ul style="list-style-type: none"> - Perform destination N_Port Login (23.4.2.1) (Fabric present)
4. ACC	0 or 0000yy	FFFFFFE	<ul style="list-style-type: none"> - OX_ID = FLOGI OX_ID - If Common Serv = N_Port, no Fabric present 	<ul style="list-style-type: none"> - Perform point-to-point destination N_Port Login (23.4.2.1)
5. F_BSY or P_BSY	0 or 0000yy	FFFFFFE	<ul style="list-style-type: none"> - Busy 	<ul style="list-style-type: none"> - retry later
6. F_RJT or P_RJT	0 or 0000yy	FFFFFFE	<ul style="list-style-type: none"> - reason code - Class not supported - Invalid S_ID - Other 	<ul style="list-style-type: none"> - FLOGI next Class (S_ID = 0 or 000yy) - FLOGI with S_ID = X or different yy - respond accordingly
7. FLOGI	FFFFFFE	0 or 0000yy	<ul style="list-style-type: none"> - Collision with other N_Port 	<ul style="list-style-type: none"> - See FC-PH
8. LS_RJT	X or XXXXyy	FFFFFFE	<ul style="list-style-type: none"> - Fabric present - reason code 	<ul style="list-style-type: none"> - reLogin with altered Service Parameters, use D_ID of LS_RJT
9. None			<ul style="list-style-type: none"> - error 	<ul style="list-style-type: none"> - perform ABTS after Sequence Timeout

These responses are characterized by the following:

- Response 1 is possible from an N_Port or Fabric.
- Response 2 is from a Fabric or an N_Port. The D_ID and S_ID values (in the response to the FLOGI Sequence) correspond to the values in the FLOGI fields, respectively, in the FLOGI Sequence (also for responses 5 and 6).
- Response 3 completes Fabric Login. The N_Port S_ID is assigned as X or XXXXyy.
- Response 4 indicates a point-to-point topology with another N_Port, which is determined by examining the Common Service Parameter which specifies N_Port or F_Port. Based on a comparison of Port_Names, either transmit PLOGI, or wait for PLOGI.
- Response 5 indicates that either the Fabric or N_Port is busy, retry later.
- Response 6 indicates a Fabric or N_Port reject. If Class is not supported, retry Login with another Class with a numerically higher value. If the reason code is Invalid S_ID, then retry FLOGI with a different value of yy, or with a value of X (see 23.3.2.2). For other reject reasons, the N_Port shall respond accordingly.
- Response 7 indicates a point-to-point attachment and a collision with a FLOGI from the attached N_Port. The N_Port shall respond with ACC. The Common Service Parameters shall contain the same information as FLOGI, but shall indicate that an N_Port is transmitting the Data. Port_Name and Node_Name shall be included, but all Classes of Service shall be indicated as invalid. The N_Port shall compare the Port_Name received to the Port_Name it transmitted. If this N_Port's value is lower, it shall end this Exchange and wait for a PLOGI from the attached N_Port. In Class 1, if this N_Port's value is lower, it shall become the Connection Recipient (see clause 28) for this Connection. In Class 1, if its value is higher, it shall become the Connection Initiator for this Connection. If its value is higher, it shall transmit a PLOGI (see 23.4.2.3) as part of a new Dedicated Connection. The Dedicated

Connection associated with FLOGI shall be removed by the normal method to remove a Dedicated Connection in Class 1. See 23.6.4 for a description of N_Port_Names. See 23.4.2.3 for a description of point-to-point destination N_Port Login.

- Response 8 indicates that the Login request is being rejected for a reason specified in the LS_RJT frame. The FLOGI request may be retried if the appropriate corrective action is taken.

- Response 9 indicates that a Link error has occurred.

NOTE – When an N_Port originates an Exchange using an N_Port Identifier of unidentified (binary zeroes or 0000yy), its N_Port Identifier may change between transmitting a request Sequence (Login) and receiving the reply Sequence (Accept).

23.6 N_Port Service Parameters

Figure 59 provides the payload format of the FLOGI or PLOGI Extended Link Service commands and their respective ACC replies.

Item	Size (Bytes)
LS_Command code	4
Common Service Parameters	16
Port Name	8
Node or Fabric Name	8
Class 1 Service Parameters	16
Class 2 Service Parameters	16
Class 3 Service Parameters	16
Class 4 Service Parameters	16
Vendor Version Level	16
Reserved	16
Services Availability (see note)	8
Reserved (see note)	116

Figure 59 – FLOGI, PLOGI, or ACC Payload

NOTE – These fields are only present when the Payload Length bit (see 23.6.2.3) is set to 1. When the Payload Length bit is set to 0, these fields are

dpANS X3.xxx-199x

not present in the payload, i.e., the payload is 128 bytes long.

23.6.1 N_Port Common Service Parameters

Table 98 provides a summary of N_Port Common Service Parameters based on x3.230-1994 (FC-PH) table 98.

Table 98 – N_Port Common Service Parameter Applicability										
Service Parameter	Wd	Bits	N_Port Login Class				Fabric Login Class			
			1	2	3	4	1	2	3	4
FC-PH Version										
Highest Version	0	31-24	y	y	y	y	y	y	y	y
Lowest Version	0	23-16	y	y	y	y	y	y	y	y
Buffer-to-Buffer Credit	0	15-0	y	y	y	n	y	y	y	n
Common Features										
Continuously Increasing (C)	1	31	y	y	y	y	n	n	n	n
Random Relative Offset (O)	1	30	y	y	y	y	n	n	n	n
Vendor Version Level	1	29	y	y	y	y	y	y	y	y
N_Port/F_Port	1	28	y	y	y	y	y	y	y	y
Alternate BB_Credit Management (see 26.5)	1	27	y	y	y	y	y	y	y	y
E_D_TOV Resolution (see 23.6)	1	26	y	y	y	y	n	n	n	n
Payload Length (see 23.6.2.3)	1	16	y	y	y	y	y	y	y	y
Buffer-to-Buffer Receive Data field Size	1	11-0	y	y	y	y	y	y	y	y
N_Port Total Concurrent Sequences	2	31-16	y	y	y	y	n	n	n	n
Relative Offset by Info Category	2	15-0	y	y	y	y	n	n	n	n
E_D_TOV ⁽³⁾ ⁽⁴⁾	3	31-0	PTP	PTP	PTP	n	n	n	n	n
Notes 1) "y" indicates yes, applicable 2) "n" indicates, not applicable 3) PTP indicates the applicability only to Point-to-Point. 4) R_A_TOV and E_D_TOV provided by the F_Port as Fabric Common Service Parameters during Fabric Login are not shown in this table.										

23.6.2 N_Port Common Service parameters - Fabric Login

Enhanced N_Port Common Service parameters used during Fabric Login are illustrated in figure 61.

word 0 1 2 3	31	16	15	0
	FC-PH / FC-PH-2 / FC-PH-3 Version		Buffer-to-buffer Credit (Pt to Pt)	
	HHHHHHHH LLLLLLLL		BBBBBBBBBBBBBBBB	
	rrrVN Arrr rrrr rrrP		rrrr FFFF FFFF FFFF	
	31	16	15	0
	Common Features		Buffer-to-buffer Rcv Data Field size	
	rrrVN Arrr rrrr rrrP		rrrr FFFF FFFF FFFF	
	31	16	15	0
	Total Concurrent Sequences Reserved		Relative Offset by Info Category Reserved	
	rrrrrrrr rrrrrrrr		rrrrrrrr rrrrrrrr	
	31	16	15	0
	Reserved		Reserved	
	rrrrrrrr rrrrrrrr		rrrrrrrr rrrrrrrr	

Figure 60 – N_Port Common Service Parameters - Fabric Login

23.6.2.1 FC-PH-3 version

Table 99 specifies the hexadecimal values for low and high FC-PH-3 version levels indicated in word 0, bits 31-16 of N_Port Common Service parameters.

Table 99 – FC-PH-3 Version	
Hex value	Version level
00-09	See FC-PH Tables 99 or 100
0A-0F	Reserved
10	FC-PH-2
11-1F	Reserved
20	FC-PH-3
21-FF	Reserved

23.6.2.2 Buffer-to-buffer credit

No change from FC-PH.

23.6.2.3 Common features

- **Word 1, bits 31-30**

Reserved.

- **Word 1, bits 28 (N)**

Specified in x3.230-1994 (FC-PH).

- **Word 1, bits 29, 27 (VA)**

Specified in x3.xxx-1995 (FC-PH-2).

- **Word 1, bits 26-17**

Reserved.

- **Word 1, bit 16- Payload Length (P)**

0 = 128 bytes

1 = 256 bytes

Word 1, Bit 16 indicates the length of the FLOGI payload. If Word 1 Bit 16 = 0, then the payload shall be 128 bytes, the same as specified in FC-PH-2. If Word 1 Bit 16 = 1, then the payload shall be 256 bytes.

23.6.2.4 Buffer-to-buffer Data_Field size

- **Word 1, bits 15-0 Buffer-to-buffer Receive Size (F)**

The **buffer-to-buffer Receive Data_Field Size** is a binary value (bits 15-0) which specifies the largest Data_Field Size for an FT_1 frame (17.4) that can be received by the N_Port supplying the Service Parameters as a Sequence Recipient for:

- a connect-request (**SOFc1**),
- a Class 2 Data frame, or
- a Class 3 Data frame.

Values less than 256 or greater than 2¹¹² are invalid. Values shall be a multiple of four bytes.

The buffer-to-buffer Receive Data_Field size is specified by FC-2.

23.6.3 N_Port Common Service Parameters - N_Port Login

N_Port Common Service Parameters used during N_Port Login are shown in figure 61.

word	0	31 FC-PH / FC-PH-2 Version HHHHHHHH LLLLLLLL	15 Buffer-to-buffer Credit (Pt to Pt) BBBBBBBBBBBBBBBB	0
	1	31 Common Features COVNARrr rDrrrrrP	15 Buffer-to-buffer Rcv Data Field size rrrr FFFF FFFF FFFF	0
	2	31 Total Concurrent Sequences rrrrrrr TTTTTTTT	Relative Offset by Info Category DDDDDDDDDDDDDD	0
	3	31 E_D_TOV (Pt-to-Pt) ttttttt ttttttt ttttttt ttttttt		

Figure 61 – N_Port Common Service Parameters - N_Port Login

23.6.3.1 FC-PH-3 version

Same as 23.6.2.1.

23.6.3.2 Buffer-to-buffer credit

No change from FC-PH.

23.6.3.3 Common features

- **Word 1, bits 31- 28 (COVN)**
Specified in x3.230-1994 (FC-PH).
- **Word 1, bit 27, 22 (AD)**
Specified in x3.xxx -1995 (FC-PH-2).
- **Word 1, bit 26 - E_D_TOV Resolution (R)**
0 = 1 ms
1 = 1 ns

Word 1, Bit 26 indicates the resolution of the E_D_TOV timer. If Word 1 Bit 26 = 0, then the timer shall be in increments of 1 ms. If Word 1 Bit 26 = 1, then the timer shall be in increments of 1 ns.
- **Word 1, bits 25-23, 21-17**
Reserved
- **Word 1, bit 16 - Payload Length (P)**
0 = 128 bytes
1 = 256 bytes

Word 1, Bit 25 indicates the length of the PLOGI payload. If Word 1 Bit 25 = 0, then the payload shall be 128 bytes, the same as specified in FC-PH-2. If Word 1 Bit 25 = 1, then the payload shall be 256 bytes.

23.6.3.4 Buffer-to-buffer Data_Field size

- **Word 1, bits 15-0 Buffer-to-buffer Receive Size (F)**

The **buffer-to-buffer Receive Data_Field Size** is a binary value (bits 15-0) which specifies the largest Data_Field Size for an FT_1 frame (17.4) that can be received by the N_Port supplying the Service Parameters as a Sequence Recipient for:

- a connect-request (**SOFc1**),
- a Class 2 Data frame, or
- a Class 3 Data frame.

Values less than 256 or greater than 2 112 are invalid. Values shall be a multiple of four bytes.

The buffer-to-buffer Receive Data_Field size is specified by FC-2.

23.6.3.5 Total Concurrent Sequences

No change from FC-PH.

23.6.3.6 Relative Offset by category

No change from FC-PH.

23.6.3.7 Point-to-point E_D_TOV value

Word 3 shall only be meaningful by an N_Port in a point-to-point topology. In a topology other than point-to-point, word 3 shall not be meaningful. When Word 1, Bit 26 = 0, the E_D_TOV value shall be specified as a count of 1 ms increments. When Word 1, Bit 26 = 1, the E_D_TOV value shall be specified as a count of 1 ns increments. Therefore, based on the setting of Word 1, Bit 26, a value of hex '0000000A' specifies a time period of either 10 ms or 10 ns.

The E_D_TOV value in the Accept shall be greater than or equal to the value in the PLOGI. The E_D_TOV value in the Accept shall be the value used by each N_Port. R_A_TOV shall be a value twice the E_D_TOV value in a point-to-point topology.

23.6.6 N_Port Class Service Parameters

Table 98 provides a summary of N_Port Class Service Parameters based on FC-PH-2 table 101.

Table 101 – N_Port Class Service Parameter Applicability										
Service Parameter	Wd	Bits	N_Port Login Class				Fabric Login Class			
			1/6	2	3	4	1/6	2	3	4
FC-PH Version										
Valid = 1	0	31	y	y	y	y	y	y	y	y
Service Options										
Intermix Mode	0	30	y	n	n	n	y	n	n	n
Stacked Connect-Request	0	29-28	n	n	n	n	n	n	n	n
Sequential Delivery	0	27	n	n	n	n	n	y	y	n
Dedicate Simplex	0	26	y	n	n	n	y	n	n	n
Camp-On	0	25	n	n	n	n	y	n	n	n
Buffered Class 1	0	24	y	n	n	n	y	n	n	n
Priority (see 18.9.2)	0	23	y	y	n	y	y	y	n	y
Initiator Control										
X_ID Reassignment	0	15-14	y	y	n	y	n	n	n	n
Initial Responder Process_Associator	0	13-12	y	y	y	y	n	n	n	n
ACK_0 capable	0	11	y	y	n	y	n	n	n	n
ACK_N capable	0	10	y	y	n	y	n	n	n	n
ACK generation assistance	0	9	y	y	n	y	n	n	n	n
Data compression capable	0	8	y	y	y	y	n	n	n	n
Data compression History buffer size	0	7-6	y	y	y	y	n	n	n	n
Data encryption capable	0	5	y	y	y	y	n	n	n	n
Clock synchronization capable	0	4	y	y	y	y	y	y	y	y

Table 101 – N_Port Class Service Parameter Applicability										
Service Parameter	Wd	Bits	N_Port Login Class				Fabric Login Class			
			1/6	2	3	4	1/6	2	3	4
Recipient Control										
ACK_0 capable	1	31	y	y	n	y	n	n	n	n
ACK_N capable	1	30	y	y	n	y	n	n	n	n
X_ID Interlock	1	29	y	y	n	y	n	n	n	n
Error Policy Supported	1	28-27	y	y	y	y	n	n	n	n
Categories per Sequence	1	25-24	y	y	y	y	n	n	n	n
Data compression capable	1	23	y	y	y	y	n	n	n	n
Data compression History buffer size	1	22-21	y	y	y	y	n	n	n	n
Data decryption capable	1	20	y	y	y	y	n	n	n	n
Clock synchronization capable	1	19	y	y	y	y	y	y	y	y
Reserved - Fabric specific	1	18-16	y	y	y	y	y	y	y	y
Receive Data Field Size	1	15-0	y	y	y	y	n	n	n	n
Concurrent Sequences	2	31-16	y	y	y	y	n	n	n	n
N_Port End-to-end Credit	2	14-0	y	y	n	n	n	n	n	n
Open Sequences per Exchange	3	31-16	y	y	y	y	n	n	n	n
Notes			See FC-PH or FC-PH-2 for all items without cross-references.							
1) "y" indicates yes, applicable										
2) "n" indicates, not applicable										

23.6.7 N_Port Class Service Parameters - Fabric Login

Figure 62 illustrates N_Port Class Service Parameters for Fabric Login, enhanced from x3.230-1994 (FC-PH) and X3.xxx-1995 (FC-PH-2).

word 0	31 Service Options 16 VISSQDCB PEEEEEEE	15 Initiator Control 0 DDDDDDDD DDDDDDDD
	31 Recipient Control 16 CCCCCCCC CCCCCCCC	15 Rcv Data Field size 0 rrrrr FFFF FFFF FFFF
2	31 Concurrent Sequences 16 rrrrrrrrr LLLLLLLLL	15 N_Port End-to_end Credit 0 0MMMMMMMMMMMMMMMM
3	31 Open Sequences per Exchange 16 rrrrrrrrr xxxxxxxx	15 Reserved 0 rrrrrrrrr rrrrrrr

Figure 62 – N_Port Class Service Parameters - Fabric Login

23.6.7.1 Class Validity (V)

No change from FC-PH or FC-PH-2

23.6.7.2 Service Options

- **Word 0, Bit 30-24 (ISSQDCB)**

Class 1, 2, 3, and 4

No change from FC-PH or FC-PH-2

- **Word 0, Bit 23 - Priority/Preemption (P)**

0 = Priority/Preemption not supported

1 = Priority/Preemption supported

See clause 18.9

Class 1, 2, and 4

When an N_Port performs Login with a Fabric, it shall request support for Priority/Preemption by specifying bit 23 = 1. If the Accept reply from the Fabric specifies bit 23 = 1, then both the N_Port and Fabric have agreed that Priority/Preemption is enabled.

The following set of values specifies the meaning of the combination of Word 0, bit 23:

N_Port F_Port

0	0	Neither supports
0	1	Fabric is capable of supporting.
1	0	N_Port support requested, Fabric does not support
1	1	N_Port requested, Fabric agrees, Priority/Preemption is enabled

Class 3

Word 0, bit 23 is reserved.

- **Word 0, Bit 22 - 16**

Reserved

23.6.7.3 Initiator control

This field is not meaningful during Fabric Login.

23.6.7.4 Recipient control

This field is not meaningful during Fabric Login.

23.6.7.5 Receive Data_Field Size

This field is not meaningful during Fabric Login.

23.6.7.6 Concurrent Sequences

This field is not meaningful during Fabric Login.

23.6.7.7 N_Port End-to-end Credit

This field is not meaningful during Fabric Login.

23.6.7.8 Open Sequences per Exchange

This field is not meaningful during Fabric Login.

23.6.8 N_Port Class Service Parameters - N_Port Login

Figure 62a illustrates N_Port Class Service Parameters for N_Port Login, enhanced from x3.230-1994 (FC-PH) and X3.xxx-1995 (FC-PH-2).

23.6.8.1 Class Validity (V)

No change from FC-PH or FC-PH-2

23.6.8.2 Service Options

- **Word 0, Bit 30-24 (ISSQDCB)**

Class 1, 2, 3, and 4

No change from FC-PH or FC-PH-2

word 0	31 Service Options 16 VISSQDCB PEEEEEEE	15 Initiator Control 0 XXPPZNGC CCEDDDDD
	31 Recipient Control 16 ZNXLLrSS CCCEYrrr	15 Rcv Data Field size 0 r r r r NNNNNNNNNNNN
2	31 Concurrent Sequences 16 rrrrrrrr LLLLLLLL	15 N_Port End-to_end Credit 0 OMMMMMMMMMMMMMMMMM
3	31 Open Sequences per Exchange 16 rrrrrrrr xxxxxxxx	15 Class 6 Multicast RX_ID 0 xxxxxxx xxxxxxxx

Figure 62a – N_Port Class Service Parameters - N_Port Login

• **Word 0, Bit 23 - Priority (P)**

0 = Priority not supported

1 = Priority supported

See clause 18.9

Class 1, 2, and 4

When an N_Port performs Login with another N_Port, it shall indicate support for Priority by specifying bit 23 = 1. The other N_Port indicates support for Priority by specifying bit 23 = 1 in the ACC sent as a reply. Support of Priority as an Exchange Originator means that Word 4, Bits 31-24 of the Frame Header shall specify the desired Priority and Word 4, Bits 23-16 of the Frame Header shall specify the OX_ID. Support of Priority as an Exchange Responder means that Word 4, Bits 31-24 of the Frame Header shall be ignored and Word 4, Bits 23-16 of the Frame Header shall be interpreted as the OX_ID.

Class 3

Word 0, bit 23 is reserved.

• **Word 0, Bit 22 - 16**

Reserved

23.6.8.3 Initiator control

• **Word 0, bit 5 - Data encryption capable (E)**

Class 1,2, and 3 (see 40.2)

Word 0, Bit 5

= 0 Initiator does not have data encryption capability

= 1 Initiator has data encryption capability

Class 4

Same function as Class 1 and 2.

• **Word 0, bit 4 - Clock synchronization capable (Y)**

Class 1,2,3, and 4 (see 39.4.1)

Word 0, Bit 4

= 0 Initiator does not have clock synchronization capability

= 1 Initiator has clock synchronization capability

23.6.8.4 Recipient control

• **Word 1, bit 20 - Data decryption capable (E)**

Class 1,2, and 3 (see 40.2)

Word 1, Bit 20

= 0 Recipient does not have data decryption capability

= 1 Recipient has data decryption capability

Class 4

Same function as Class 1 and 2.

• **Word 1, bit 19 - Clock synchronization capable (Y)**

Class 1,2,3, and 4 (see 39.4.1)

Word 1, Bit 19

= 0 Recipient does not have clock synchronization capability

= 1 Recipient has clock synchronization capability

23.6.8.5 Receive Data Field Size

No change from FC-PH or FC-PH-2.

23.6.8.6 Concurrent Sequences

No change from FC-PH or FC-PH-2.

23.6.8.7 N_Port End-to-end Credit

No change from FC-PH or FC-PH-2.

23.6.8.8 Open Sequences per Exchange

No change from FC-PH or FC-PH-2.

23.6.8.9 Class 6 Multicast RX_ID

When an N_Port performs Login with the Multicast Server, it shall specify the RX_ID value to be used by the Multicast Server when acknowledging the Connection Initiator. Word 3, bits 15-0 shall be the RX_ID value used by the Multicast Server.

23.6.9 Vendor Version Level

No change from FC-PH-2.

23.6.10 Services Availability

This field is reserved.

23.7 F_Port Service Parameters

23.7.1 F_Port Common Service Parameters

Figure 67 illustrates F_Port Common Service Parameters, enhanced from x3.230-1994 (FC-PH) and X3.xxx-1995 (FC-PH-2).

word 0	31	16	15	0
	FC-PH / FC-PH-2 Version		Buffer-to-buffer Credit	
	HHHHHHHH LLLLLLLL		BBBBBBBBBBBBBBBB	
1	31	16	15	0
	Common Features		Buffer-to-buffer Rcv Data Field size	
	rrrN rRMB HDrr rrrr		rrrr FFFF FFFF FFFF	
2	31	16	15	0
	R_A_TOV			
	tttttttt tttttttt tttttttt tttttttt			
3	31	16	15	0
	E_D_TOV			
	tttttttt tttttttt tttttttt tttttttt			

Figure 67 – F_Port Common Service Parameters - Fabric Login

23.7.1.1 FC-PH-3 version

Same as 23.6.2.1.

23.7.1.2 Buffer-to-buffer (F_Port) Credit

No change from FC-PH or FC-PH-2.

23.7.1.3 Common features

• **Word 1, bits 31-27**

Specified in x3.230-1994 (FC-PH).

• **Word 1, bit 26 - E_D_TOV Resolution (R)**

0 = 1 ms

1 = 1 ns

Word 1, Bit 26 indicates the resolution of the E_D_TOV timer. If Word 1 Bit 26 = 0, then the timer shall be in increments of 1 ms. If Word 1 Bit 26 = 1, then the timer shall be in increments of 1 ns.

• **Word 1, bits 25-24, 22 (MB, D)**

Specified in x3.xxx-1995 (FC-PH-2).

• **Word 1, bit 23 - Hunt Group (H)**

0 = Hunt Groups not supported.

1 = Hunt Groups supported.

Word 1, Bit 23 indicates whether or not the Fabric supports Hunt Group routing. If Word 1 Bit 23 = 0, then the Fabric shall not support Hunt Group routing. If Word 1 Bit 23 = 1, then the Fabric shall support Hunt Group routing.

• **Word 1, bits 21-17**

Specified in x3.230-1994 (FC-PH).

• **Word 1, bit 16- Payload Length**

0 = 128 bytes

1 = 256 bytes

Word 1, Bit 25 indicates the length of the ACC payload. If Word 1 Bit 25 = 0, then the payload shall be 128 bytes, the same as specified in FC-PH-2. If Word 1 Bit 25 = 1, then the payload shall be 256 bytes.

23.7.1.4 Buffer-to-buffer Data_Field size

- **Word 1, bits 15-0 Buffer-to-buffer Receive Size (F)**

The **buffer-to-buffer Receive Data_Field Size** is a binary value (bits 15-0) which specifies the largest Data_Field Size for an FT_1 frame (17.4) that can be received by the F_Port supplying the Service Parameters as a Sequence Recipient for:

- a connect-request (**SOFc1**),
- a Class 2 Data frame, or
- a Class 3 Data frame.

Values less than 256 or greater than 2 112 are invalid. Values shall be a multiple of four bytes.

23.7.1.5 E_D_TOV

When Word 1, Bit 26 = 0, the E_D_TOV value shall be specified as a count of 1 ms increments. When Word 1, Bit 26 = 1, the E_D_TOV value shall be specified as a count of 1 ns increments. Therefore, based on the setting of Word 1, Bit 26, a value of hex '0000000A' specifies a time period of either 10 ms or 10 ns.

23.7.1.6 R_A_TOV

No change from FC-PH or FC-PH-2.

23.7.2 F_Port Name

No change from FC-PH or FC-PH-2.

23.7.3 Fabric Name

No change from FC-PH or FC-PH-2.

23.7.4 F_Port Class service Parameters

Figure 67a illustrates F_Port Class Service Parameters, enhanced from x3.230-1994 (FC-PH) and X3.xxx-1995 (FC-PH-2).

word 0	31	16	15	0
	Service Options		Initiator Control	
1	31	16	15	0
	Recipient Control Reserved for Fabric use		Rcv Data Field size	
2	31	16	15	0
	Concurrent Sequences Not Meaningful		N_Port End-to_end Credit Not Meaningful	
3	31	16	15	0
	CR_TOV			
	tttttttt	tttttttt	tttttttt	tttttttt

Figure 67a – F_Port Class Service Parameters - Fabric Login

23.7.4.1 Class Validity

No enhancements to FC-PH or FC-PH-2

23.7.4.2 Service Options

Service Options (E) shall specify Class of Service capabilities supported or required by the Fabric supplying the Service Parameters. (FC-PH)

Service options shall specify optional features of a Class of Service supported by the N_Port supplying the Service Parameters. (FC-PH-2)

- **Word 0, Bit 31-24 (VISSQDCB)**

Class 1, 2, 3, and 4

No change from FC-PH or FC-PH-2

- **Word 0, Bit 23 - Priority (P)**

Class 1, 2, and 4

0 = Priority/Preemption not supported

1 = Priority/Preemption supported

See clause 18.9

Class 3

Word 0, bit 23 is reserved.

23.7.4.3 Initiator control

No change from FC-PH or FC-PH-2.

23.7.4.4 Recipient control

No change from FC-PH or FC-PH-2.

23.7.4.5 Receive Data_Field Size

No change from FC-PH or FC-PH-2.

23.7.4.6 Concurrent Sequences

No change from FC-PH or FC-PH-2.

23.7.4.7 N_Port End-to-end Credit

No change from FC-PH or FC-PH-2.

23.7.4.8 Open Sequences per Exchange

No change from FC-PH or FC-PH-2.

23.7.4.9 C_R_TOV

No change from FC-PH-2.

23.7.5 Vendor Version Level

This field is reserved.

23.7.6 Services Availability

This field returns information regarding the Fabric's ability to route to the defined well-known addresses.

- **Word 0, bits 31-11 - Reserved**

- **Word 0, bit 10 - Multicast Server**

When set to 1, this bit shall indicate that the Fabric supports routing to the well-known Multicast Server address identifier (hex 'FFFFFF5'). When set to 0, this bit shall indicate that the Fabric does not support routing to the well-known Multicast Server address identifier.

- **Word 0, bit 9 - Clock Synchronization Server**

When set to 1, this bit shall indicate that the Fabric supports routing to the well-known Clock Synchronization Server address identifier (hex 'FFFFFF6'). When set to 0, this bit shall indicate that the Fabric does not support routing to the well-known Clock Synchronization Server address identifier.

- **Word 0, bit 8 - Security Key Distribution Server**

When set to 1, this bit shall indicate that the Fabric supports routing to the well-known Key Distribution Server address identifier (hex 'FFFFFF7'). When set to 0,

this bit shall indicate that the Fabric does not support routing to the well-known Key Distribution Server address identifier.

- **Word 0, bit 7 - Alias Server**

When set to 1, this bit shall indicate that the Fabric supports routing to the well-known Alias Server address identifier (hex 'FFFFFF8'). When set to 0, this bit shall indicate that the Fabric does not support routing to the well-known Alias Server address identifier.

- **Word 0, bit 6 - Quality of Service Facilitator**

When set to 1, this bit shall indicate that the Fabric supports routing to the well-known Quality of Service Facilitator address identifier (hex 'FFFFFF9'). When set to 0, this bit shall indicate that the Fabric does not support routing to the well-known Quality of Service Facilitator address identifier.

- **Word 0, bit 5- Management Server**

When set to 1, this bit shall indicate that the Fabric supports routing to the well-known Management Server address identifier (hex 'FFFFFFA'). When set to 0, this bit shall indicate that the Fabric does not support routing to the well-known Management Server address identifier.

- **Word 0, bit 4- Time Server**

When set to 1, this bit shall indicate that the Fabric supports routing to the well-known Time Server address identifier (hex 'FFFFFFB'). When set to 0, this bit shall indicate that the Fabric does not support routing to the well-known Time Server address identifier.

- **Word 0, bit 3 - Directory Server**

When set to 1, this bit shall indicate that the Fabric supports routing to the well-known Directory Server address identifier (hex 'FFFFFFC'). When set to 0, this bit shall indicate that the Fabric does not support routing to the well-known Directory Server address identifier.

- **Word 0, bits 2-0 - Reserved**
- **Words 1-7 - Reserved**

23.8 Procedure to estimate end-to-end Credit

No change from FC-PH or FC-PH-2.

24 Exchange, Sequence, and sequence count management

Enhancements to FC-PH and FC-PH-2 are specified.

24.3 Summary rules

24.3.1 Exchange management

i) In Process policy with infinite buffers under Class 1 operation, a Sequence is complete with regard to Data content if at least the first and last Data frames were received as valid frames without rejectable errors being detected. For Class 3 Process policy with infinite buffers, a sequence is complete if a frame of another sequence is received or E_D_TOV expires before the last frame of the current sequence is received.

24.3.7 Normal ACK processing

g) ACK_1 or ACK_N frames with an ACK_CNT of 1, or an ACK_0 frame, shall be transmitted during X_ID interlock, (see 25.3.1 and 24.5.4) and in response to a connect-request (see 28.4.1).

24.3.11 Sequence errors - Class 3

Errors within a Sequence may only be detected by the Sequence Recipient.

24.3.11.1 Rules common to all Discard policies

NOTE – The following is identical to FC-PH, 24.3.11.

In both Discard policies, the Sequence Recipient shall discard Sequences in the same manner as in Class 1 and 2 with the exception that an ACK indication of Abort Sequence shall not be transmitted. In discard policy, the Recipient shall discard frames received after the point at which the error is detected. Individual FC-4s or upper levels may recover the entire Sequence or only that portion after which the error is detected.

- a) The types of errors that shall be detected by an N_Port include:
- detection of a missing frame based on timeout, or
 - detection of an internal malfunction.

b) If a Recipient detects an internal error, it shall abnormally terminate the Sequence, post the appropriate status, and notify the FC-4 or upper level. One or more Sequences shall not be delivered based on single or multiple Sequence discard Error Policy.

c) If a Recipient detects a missing frame, it shall abnormally terminate the Sequence, post the appropriate status, and notify the FC-4 or upper level. One or more Sequences shall not be delivered based on single or multiple Sequence discard Error Policy.

d) In the Discard multiple Sequences Error Policy in Class 3, the Sequence Recipient shall not be required to utilize a timeout value of R_A_TOV following detection of a missing frame. Therefore, frames may be discarded for an Exchange forever if other detection mechanisms are not utilized by the Sequence Initiator.

e) Notification of the Sequence error condition to the Initiator is the responsibility of the FC-4 or upper level.

24.3.11.2 Process with infinite buffers Error Policy

In process Policy, the Recipient shall ignore errors detected on all frames, or timeout errors. However, such errors shall be reported to an upper level.

NOTE – Ignoring an error on the first frame of a Sequence or an Exchange may cause the frame to be delivered to the wrong Recipient.

24.8 Status blocks

24.8.1 Exchange Status Block

An Exchange Status Block is a logical construct used to associate the OX_ID, RX_ID, D_ID and S_ID of an Exchange. The Status Block is used throughout the Exchange to track the progress of the Exchange and identify which N_Port holds the initiative to transmit Sequences. The Exchange Status Block shall continue to exist even following X_ID Invalidation, since the Operation_Associator is used to locate the ESB (use of a Process_Associator may also be required).

The Exchange Status Block shall record Exchange status information and Sequence Status for a number of Sequences received as a

Sequence Recipient. The Exchange Status Block is supplied in the RES Link Services request. Equivalent information to track transmitted Sequences is required by the Sequence Initiator for internal tracking of Exchange progress but is not required to be supplied to any other N_Port. The Sequence Status is stored in the Exchange Status Block in the oldest to newest order. The oldest Sequence is dropped out of the ESB when new Sequence status is added

Table 103 – Exchange Status Block	
Item	Size - Bytes
PRIORITY* (if enabled)	1
OX_ID/with priority enabled	2/1
RX_ID	2
Originator address identifier (High order byte - reserved)	4
Responder Address Identifier (High order byte - reserved)	4
E_STAT	4
reserved	4
Service Parameters	112
Oldest Sequence Status (SSB format- first 8 bytes)	8
Intermediate Sequence Status (SSB format-first 8 bytes)	X*8
Newest Sequence Status (SSB format-first 8 bytes)	8

* MSB is Preemption Flag

E_STAT

- **Bit 31-22**

No enhancements to FC-PH or FC-PH-2

- **Bit 21- Priority Enabled**

0 = Priority/Preemption not enabled

1 = Priority/Preemption enabled

Priority/Preemption enabled reflects the condition set on login for Word 4, Bits 31-16 of the frame header.

- **Bits 20-0 - Reserved**

24.8.2 Sequence Status Block

A Sequence Status Block is a logical construct used to track the progress of a single Sequence by an N_Port on a frame by frame basis. A Sequence Status Block shall be Opened and maintained by the Sequence Recipient for each Sequence received in order to support the RSS Link Service request. Information equivalent to an SSB is required for the Sequence Initiator to track Sequence progress internally, but is not required to be supplied to any other N_Port

Table 104 – Sequence Status Block	
Item	Size-Bytes
SEQ_ID	1
reserved	1
Lowest SEQ_CNT	2
Highest SEQ_CNT	2
S_STAT	2
Error SEQ_CNT	2
Frame header Word 4, Bits 31-16	2
RX_ID	2
reserved	2

Frame header Word 4, Bits 31-16: When priority is enabled, this field shall contain the current priority in the high order byte and the OX_ID in the low order byte. When priority is not enabled, this field shall contain the OX_ID.

S_STAT

- **Bit 15-0**

No enhancements to FC-PH or FC-PH-2

dpANS X3.xxx-199x

25 Association Header management and usage

No enhancements from FC-PH or FC-PH-2.

26 Flow control management

No enhancements from FC-PH or FC-PH-2.

27 Segmentation and reassembly

No enhancements from FC-PH or FC-PH-2.

28 Connection management

Enhancements to FC-PH as specified.

28.1 Introduction

Preempting a Dedicated Connection

Interrupting and removing a Class 1 or Class 6 Dedicated Connection between N_Ports and establishing a new Class 1 or Class 6 Dedicated Connection between an unconnected N_Port and one or more of the previously connected N_Ports is Preemption. A preemption is initiated by a N_Port sourcing a Preemption Connection Request frame (an **SOFc1** with the Preemption flag set, Word 4 bit 31) to the Fabric. The preempting N_Port then receives (1) a reject link response frame (F_RJT) with either a "Preemption Request Rejected" or a "Preemption Not Enabled" reason code, or (2) a connection acknowledge (ACK_1 or ACK_N) with an **SOFn1** having the appropriate S_ID and D_ID fields of the preemption request frame. When the ACK is received a dedicated connection has been established. If an F_RJT is received no connection has been established and the preemption request process has ended.

NOTE – Fabric resolution of a preemption request may be based on the priority of the connection request (established when the connection request was processed by the Fabric) and the priority of the preemption request as provided to the Fabric in Word 4, bits 30-24 of the preemption request SOFc1 header. If priority is used for preemption request resolution, a preemption request will be rejected with a "Preemption Request Rejected" reason code if the preemption request priority is equal to or less than the connection being preempted.

Once a preemption request results in a Dedicated Connection all Dedicated Connection and disconnection rules defined in FC-PH shall be followed.

28.4 Connect/disconnect rules

28.4.1 Connect-request rules

The following sections specify the rules governing the behavior of the source and destination of the connect-request.

28.4.1.1 Source of connect-request

d) A Dedicated Connection is established when the connect-request frame has been responded

to by an ACK frame. A proper response frame consists of:

- An ACK_1, ACK_N, or ACK_0 frame with:
 - An **SOFn1** delimiter
 - an S_ID of (B) and a D_ID of (A)
 - an **EOFn** or **EOFt** delimiter

28.5 Establishing a Connection

28.5.4 Destination of a connect-request

When N_Port(B) is not connected, but is available, and it receives a connect-request as the destination N_Port, N_Port (B) transmits the appropriate ACK frame (ACK_1, ACK_N, or ACK_0) to N_Port (A) which is requesting the connection. After the ACK frame has been transmitted with **SOFn1**, a Dedicated Connection is established with N_Port (A) as the Connection Initiator and N_Port (B) as the Connection Recipient. After a Connection has been established, N_Port (B) may initiate Sequences with N_Port (A) using an **SOFi1** delimiter.

If N_Port (B) is not connected, but is busy, and it receives a connect-request as the destination N_Port from N_Port (A), it responds with P_BSY with an **EOFdt** delimiter.

See 28.4.1 for the rules which a destination N_Port of a connect-request shall follow.

28.9 Connection Preemption

The procedure for preempting a Dedicated Connection is specified in this subclause.

28.9.1 Applicability

This preemption process applies only to Class 1 and Class 6 Service. Other preemption processes may be defined that apply to other connection oriented classes of service.

28.9.2 Topology Model

An N_Port that uses preemption shall have the ability to be connected to another N_Port through a Fabric.

28.9.3 Rules for Preemption

The following subsections specify the rules governing the behavior of the preemptor (P), pre-

empted source (PS) or destination (PD), and the preemption destination (PnD).

28.9.3.1 Preemptor (P)

The following rules specify the procedure for preempting a Dedicated Connection with respect to the Preemptor.

a) An N_Port shall initiate a preemption request using a Data (Device_Data or Link_Data) frame directed to the desired destination N_Port. The **SOFc1** preemption request frame shall be formed as follows:

- An **SOFc1** delimiter
- a Data (Device_Data or Link_Data) frame
- an S_ID of the P N_Port and a D_ID of the PnD N_Port(s)
- the E_C bit (F_CTL bit 18) shall be set = 0
- the Unidirectional bit (F_CTL bit 8) shall be set = 0 for bidirectional Connection, and = 1 for a unidirectional Connection
- the preemption flag bit (Word 4, bit 31) shall be set = 1.
- an **EOFn** or **EOFt** ending delimiter

b) The Data Field of the **SOFc1** preemption request frame shall be limited to the smaller of

- the maximum buffer-to-buffer Receive_Data_Field size specified by the Fabric, or
- the maximum Receive_Data_Field size specified by the destination N_Port.

c) After the P N_Port transmits the **SOFc1** frame it shall wait for the response frame before transmitting another frame for this sequence. Additional sequences for this connection shall not be initiated until the Dedicated Connection is established.

d) A Dedicated Connection is established when the **SOFc1** frame has been responded to by an ACK (ACK_1 or ACK_N) frame. A proper response frame consists of:

- an ACK_1, ACK_N, or ACK_0 frame with:

- an **SOFn1** delimiter, and
- an S_ID of the PnD and a D_ID of the P, and
- an **EOFn**, or **EOFt** delimiter

e) An alternate response frame is also possible from the PnD N_Port:

- a P_BSY or P_RJT frame with:
 - an **SOFn1** delimiter, and
 - an S_ID of the PnD and a D_ID of the P, and
 - an **EOFdt** delimiter

f) An alternate response frame is also possible from the Fabric F_Port:

- a F_BSY or F_RJT frame with:
 - an **SOFn1** delimiter, and
 - an S_ID of the PnD and a D_ID of the P, and
 - an **EOFdt** delimiter

g) After a Dedicated Connection is established, the P N_Port shall be the Connection Initiator and the PnD(s) shall be the Connection Recipient(s).

h) After a Dedicated Connection is established (i.e., the ACK to the **SOFc1** preemption request has been received), the Connection Initiator may continue transmitting its initial Sequence and initiate other Sequences with **SOFi1** up to the Connection Recipients ability to support Concurrent Sequences.

28.9.3.2 Preempted Source (PS)

The following rules specify the procedure for a preempted source. The PS is the connection initiator N_Port for a Class 1 or Class 6 connection.

a) If a basic link service frame consisting of:

- an PRMT command with:
 - an **SOFc1** delimiter, and
 - an S_ID of the P and a D_ID of the PS, and

- an **EOFdt** delimiter

is received by a connection initiator N_Port, that N_Port's Dedicated Connection has been removed. This PS N_Port should notify its host that its Dedicated Connection has been preempted.

28.9.3.3 Preempted Destination(s)(PD)

The following rules specify the procedure for a preempted destination. The PD is the connection recipient N_Port for a Class 1 or Class 6 connection.

- a) If a basic link service frame consisting of:
- an PRMT command with:
 - an **SOFn1** delimiter, and
 - an S_ID of the P and a D_ID of the PD, and
 - an **EOFdt** delimiter

is received by a connection recipient N_Port, that N_Ports Dedicated Connection has been removed. This PD N_Port should notify its host that its Dedicated Connection has been preempted.

28.9.3.4 Preemption Destination(s) (PnD)

The following rules specify the procedure for a preemption destination (PnD). A PnD is any N_Port, connected or not, that is addressed by the D_ID in a **SOFc1** preemption request frame.

- a) If an **SOFc1** preemption request frame is received by an N_Port not connected, and this N_Port is busy, the N_Port shall respond with P_BSY with an **EOFdt** delimiter as specified in FC-PH clause 28.4.1.1 item e.
- b) If an **SOFc1** preemption request frame is received by an N_Port not connected, and this N_Port rejects the preemption request, the N_Port shall respond with a P_RJT with an **EOFdt** delimiter as specified in FC-PH clause 28.4.1.1 item e.
- c) If an **SOFc1** preemption request frame is received by an N_Port previously connected (i.e., connected prior to being preempted) or not connected and not busy, this N_Port shall respond with the proper response frame. A proper response frame shall be:

- an ACK_1, ACK_N, or ACK_0 frame with:

- an **SOFn1** delimiter, and
- an S_ID of the PnD N_Port and a D_ID of the P, and
- an **EOFn**, or **EOFt** delimiter

A dedicated connection is established with the PS N_Port. The PnD N_Port(s) shall be the Connection Recipient(s) and the PS N_Port shall be the Connection Initiator.

- d) If a PnD N_Port receives a preemption request frame after it has transmitted a connection-request frame it should requeue its own request for transmission at a later time and respond with the proper response frame to the PS N_port.

NOTE – The preemption destination N_Port requeues its original connection-request because the Fabric has discarded it. The PnD N_Port needs to adjust its end-to-end Credit_CNT to account for the discarded connection-request.

If stacked connection-requests are being employed, the connection-request shall not be requeued by the PnD N_Port.

28.9.4 Connection Rules

Once a connection is established as a result of a preemption request, all rules specified in FC-PH or FC-PH-2 for normal Class 1 or Class 6 connections shall be followed.

28.9.5 Remove Connection Rules

All rules Specified in FC-PH or FC-PH-2 to remove Class 1 or Class 6 connections shall be followed.

28.10 Establishing a Connection Using Preemption

A Dedicated Connection is established between a preemption requesting (Connection Initiator) N_Port and preemption destination(s) (Connection Recipient(s)) N_Port(s) following the successful completion of the Preemption process specified in sub-clause 28.9.

28.10.1 Connection Initiator

When the FC-2 protocol layer receives a request from an FC-4 or upper level to initiate a Class 1 or Class 6 sequence using preemption, the N_Port shall attempt to establish a Class 1

Table 111A – Responses to Preemption Requests						
Event	SOF	D_ID	S_ID	Frame	EOF	N_Port Action
1.	SOFc1	B, ...	A	Data Frame	EOFn	- Transmit Preemption Request - Wait for confirmation frame
2.	SOFn1	A	B	F_RJT	EOFdt	- Preemption Failed. Fabric Rejected request.
3.	SOFn1	A	B	F_BSY	EOFdt	- Preemption Failed, Fabric Busy.
4.	SOFn1	A	B	P_BSY	EOFdt	- Busy N_Port, Connection Removed.
5.	SOFn1	A	B	P_RJT	EOFdt	- N_Port Rejected, Connection Removed.
6.	SOFn1	A	B	ACK_1/ ACK_N/ ACK_0	EOFn/ EOFdt	- Dedicated connection Established - Continue Transmitting Sequence - Sequence/Connection Ended.
7.	SOFc1	A	Any	Connect Request Frame	EOFn	- Requeue Preemption Request Associated with Event 1. - Respond with SOFn1 on ACK_1, ACK_N, ACK_0, or P_BSY.
8.						- Time-out, no response frame - Perform Link Reset Protocol (see FC-PH 16.6.5)
9.	SOFn1	PS or PD	A	PRMT	EOFdt	- Dedicated Connection Preempted - Notify Host, Preempted.

or Class 6 connection with the destination N_Port(s) using an **SOFc1** preemption request frame (preemption flag set = 1) as part of a Sequence initiation.

The N_Port initiates a preemption request using the rules defined in sub-clause 28.9

Table 111A defines event 1 as the preemption request and events 2 through 8 as possible responses. Event 9 defines the response of the preempted source or destination.

Event 1

A preemption Request is transmitted by N_Port (A) with an **SOFc1** delimiter with a destination address of N_Port (B) and the preemption flag set = 1 (word 4, bit 31).

Event 2

An F_RJT indicates that the Fabric is unable to establish the Dedicated Connection or has re-

jected the request. A dedicated connection has not been established. The reason code specifies the cause.

Event 3

An F_BSY indicates that the Fabric is busy and was unable to service the preemption request. A Dedicated connection has not been established.

Event 4

A P_BSY indicates that the destination N_Port link facility is temporarily occupied with other activities and is unable to accept the preemption request. Try again later.

Event 5

A P_RJT indicates that the destination N_Port is unable to establish a Dedicated Connection. The reason code specifies the cause.

Event 6

An ACK_1, ACK_N, or ACK_0 indicates that the preemption request has been serviced and a Dedicated connection has been established. N_Port (A) is connected to N_Port (B).

- a) N_Port (A) is the Connection Initiator and N_Port (B) is the Connection Recipient.
- b) N_Port (A) may continue transmitting the Sequence initiated (**EOFn**), or the Sequence which initiated the Connection may be complete (**EOft**).
- c) N_Port (A) may initiate other Sequences with the same destination N_Port (B) up to the maximum number of Sequences defined by the Service Parameters obtained from (B) during Login.
- d) The connected N_Port (B) may initiate Sequences using **SOFi1** to start each Sequence when the Connection is bidirectional. The number of active Sequences is limited by the Service parameters provided by N_Port (A) during Login.

Event 7

N_Port (A) shall requeue the **SOFc1** sent to the Fabric in Event 1 and may respond to the **SOFc1** received with and ACK_1, ACK_N, ACK_0, or P_BSY. Once this connection is completed N_Port (A) may re-send the **SOFc1** preemption request frame to the Fabric.

Event 8

If a frame response is not received within the time-out period (E_D_TOV), a link time-out shall be detected and the Link Reset Protocol shall be performed (see FC-PH 16.6.5)

See FC-PH 28.4.1 for the rules which a source N_Port of a connect-request shall follow.

Event 9

When a connected source (i.e. Connection Initiator) or destination (connection recipient), receives a PRMT, the dedicated connection has been preempted and no longer exists. The N_Port should notify its host that the Sequence(s) were abnormally terminated due to the connection being preempted.

28.10.2 Preemption Destination

If an **SOFc1** preemption request frame is received by an N_Port previously connected (i.e., connected prior to being preempted), it shall transmit the appropriate ACK frame (ACK_1 or ACK_N) to the P N_Port. After the ACK frame has been transmitted with the **SOFn1**, a Dedicated Connection is established with the P N_Port as the Connection Initiator and this destination N_Port(s) as Connection Recipient(s). After a Connection has been established, this Destination N_Port may initiate Sequences with the preemptor N_Port using an **SOFi1** delimiter, if the Connection is bi-directional (note: Class 6 dedicated connections are uni-directional).

When an un-connected N_Port receives a preemption request it shall respond normally for a Class 1 connection request, as specified in FC-PH 28.5.4.

29 Error detection and recovery

This clause describes the changes that are made in FC-PH-3 to support the E_D_TOV timer resolution enhancement.

29.2.1.2 E_D_TOV

The following replaces the second paragraph of this section in FC-PH.

When an N_Port performs N_Port Login in a point-to-point topology, the Common Service Parameters provided by each N_Port specify a value for E_D_TOV. If the two values differ, the longer time shall be used by each N_Port. An N_Port may determine another N_Port's value for E_D_TOV via the Read Timeout Value (RTV) Link Service command (see 21.4.13). Timeout values as specified in the Payload of the Accept are counts of either 1 ms or 1 ns increments, depending on the resolution specified. Therefore, a value of hex '0000000A' specifies a time period of either 10 ms or 10 ns.

29.6 Exchange integrity

Process with infinite buffering

The Process with infinite buffering Error Policy does not require that a Sequence be complete or that any previous Sequences be deliverable. Process policy allows an N_Port to utilize the Data Field of invalid frames under certain restrictive conditions (see 17.8.1 and 17.8.2). The Process with infinite buffering Error Policy is intended for applications such as a video frame buffer in which loss of a single frame has minimal effect or no effect on the Sequence being delivered. Frames shall be delivered to the FC-4 or upper level in the same order as received.

The above shall also apply to Process with infinite buffering in Class 3.

30 Hunt Group

No enhancements from FC-PH or FC-PH-2.

31 Multicast

Enhancements to FC-PH-2 as specified.

31.1 Introduction

Multicast provides a service based on Fabric routing of Class 3 or Class 6 frames. For a multicast connection the Fabric routes frames from a source N_Port to many destination N_Ports.

31.2 Class 6 Multicast

Class 6 multicast provides a reliable service based on Fabric routing of Class 6 frames. A Class 6 **SOFc1** is identical to a Class 1 **SOFc1**. The Fabric recognizes the multicast D_ID and performs the Class 6 multicast function, i.e., it causes the frame to be delivered to every destination in the Multicast Group. A Multicast Group is the set of N_Ports to which a frame being multicast is delivered. An N_Port becomes a member of a Class 6 Multicast Group when a dedicated connection is established between it and another N_Port. An N_Port is no longer a member of a Class 6 Multicast Group when the multicast connection is dissolved.

NOTE – A system implementation may provide less than reliable multicast service by implementing a single Sequence with infinite credit.

31.2.1 Class 6 Multicast Routing

All routing of multicast frames is done by the Fabric, based on the recognition that the D_ID of the transmitted frame is a multicast address. The exact frame that entered the Fabric is replicated to every destination N_Port indicated. The Fabric shall not alter the frame header or the frame contents in any manner during this replication.

Figure 89a illustrates the multicast routing. N_Port B, C, D and E are members of a Multicast group. N_Port A is the message sender which may or may not be a member of the group.

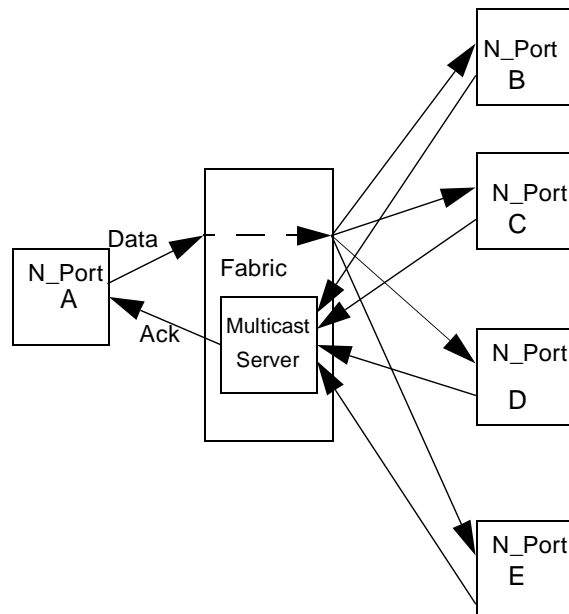

Figure 89a – Class 6 Multicast Routing

31.2.2 Class 6 Multicast Rules

- The Sequence Initiator of the Multicast message shall follow the uniqueness rules for OX_ID, SEQ_ID, and Sequence Count. The Sequence Initiator shall be the Connection Initiator for all multicast sequences. RX_ID for the Sequence shall be set to an appropriate value (established during Login) by the multicast server.
- D_ID in all frames shall address the multicast alias of the multicast group. S_ID in all frames shall be the N_Port Identifier of the Sequence Initiator.
- The Fabric shall not alter the frame in any way. The Fabric shall simply replicate each frame to every group member.
- Sequence Initiative shall not be transferred.
- All Class 6 multicast frames shall be routed as uni-directional Dedicated Connections, regardless of the state of the Simplex bit in the CS_CTL Field (word 1 bit 31).

- f) If any Multicast Group member is not able to receive frames for any reason the Multicast Server shall respond to the connection request with a P_RJT.
- g) Class 1 service parameters, as specified during Login, shall be used to manage Class 6 multicast connections.
- h) The effect of preemption of one destination N_Port on the remaining N_Ports in the multicast group is implementation-dependent.

31.2.3 Class 6 Multicast Server

To provide a single consistent response to the requesting N_Port, all destination N_Port responses shall be managed by a multicast server (at well known address 'FFFFF5'). Based upon the type of responses returned from the destination N_Ports (i.e. ACK, P_RJT, or P_BUSY), the multicast server shall return a single, ACK, busy, or reject (with a valid reason code) frame to the requesting N_Port as follows:

- a) Respond with an ACK only if all destinations respond with an ACK before E_D_TOV has expired since the sending of the last multicast Data frame.
- b) Respond with a busy, with a "partial multicast busy" reason code (20.3.3.2), if one or more destinations respond with a busy.
- c) Respond with a reject, with a "multicast error" reason code (20.3.3.3), if one or more destinations respond with a reject, or not all destinations have responded with an ACK within E_D_TOV.
- d) Respond with a reject, with an **EOFdt** delimiter and a "multicast error terminate" reason code (20.3.3.3), if one or more destinations respond with an ACK, BSY, or RJT frame with an **EOFdt** delimiter.
- e) Respond with a Link Reset (LR) if one or more destinations respond with a Link Reset, or if one or more, but not all, destinations respond with a Link Reset Response (LRR).
- f) Respond with a Link Reset Response (LRR) only if all destinations respond with an LRR.

Once a Class 6 connection is established, end-to-end credit is managed between the Connection Initiator and the multicast server.

31.2.4 Class 6 Multicast recovery

If the multicast Connection Initiator receives from the Multicast Server a BSY or RJT, the Connection Initiator shall perform a Link Reset. If a RJT with an **EOFdt** delimiter is received, the Connection Initiator shall terminate the multicast connection.

31.3 Class 3 Multicast

Class 3 multicast provides a service based on Fabric routing of Class 3 frames. When the Fabric receives a Class 3 frame that is to be multicast, it causes the frame to be delivered to every destination in the Multicast Group. A Multicast Group is a list of N_Ports to which a frame being multicast is delivered. A Multicast Group is managed by the Alias Server, which handles the registration of N_Ports into a Multicast Group, and the de-registration of N_Ports from a Multicast Group. The Alias Server is not involved in the routing of multicast frames.

Class 3 multicast routing is specified in 31.3.2 in more detail.

31.3.1 Registration and De-registration

The registration/de-registration by an N_Port as a member of a Multicast Group with the Alias Server is specified in clause 32. An N_Port may register itself as a member of one or more Multicast Groups. An N_Port may register a list of N_Ports as members of one or more Multicast Groups. The third party authorization for registration or de-registration is outside the scope of the document.

31.3.2 Multicast Routing

All routing of multicast frames is done by the Fabric, based on a recognition that the D_ID of the transmitted frame is an MG_ID Alias. The exact frame that entered the Fabric is replicated to every destination N_Port in the Multicast Group associated with the MG_ID of the frame. The Fabric shall not alter the frame header or the frame contents in any manner during this replication.

The Sequence Initiator performs no special function to transmit a frame to be multicast other than use a D_ID indicating the MG_ID

and the Multicast Group Service Parameters, rather than the Login Service Parameters. For example, the Receive Data Field Size for a multicast frame may be different than the Receive Data Field Size for a unicast frame.

If the Sequence Recipient is a member of a Multicast Group, it shall recognize the MG_ID as an Alias and accept the frame.

Class1, Class 2, and Class 4 frames with a D_ID equal to an MG_ID shall be rejected by the Fabric.

Figure 89b illustrates the multicast routing. N_Port B, C, D, and E are members of a Multicast Group. N_Port A is the message sender which may not be a member of the group. If it is a member, it may optionally receive the same message (see FC-GS.).

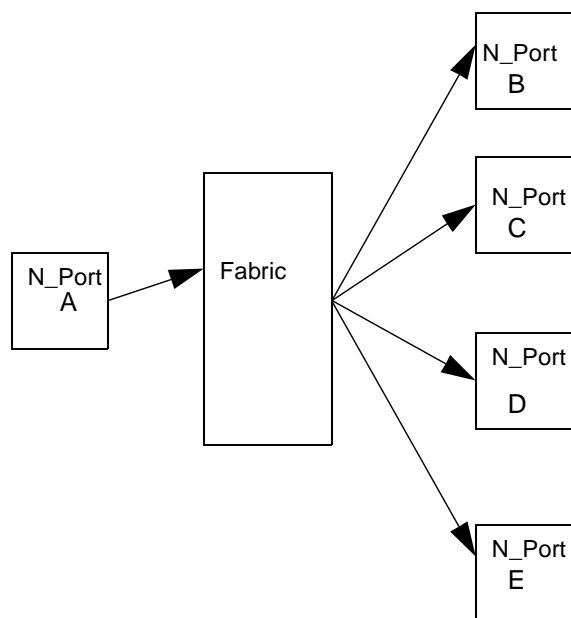

Figure 89b – Class 3 Multicast Routing

31.3.3 Class 3 Multicast rules

- a) The Sequence Initiator of the Multicast message shall follow the uniqueness rules for OX_ID, SEQ_ID, and Sequence Count. RX_ID for the Sequence shall be set to hex 'FFFF'.
- b) D_ID in all frames shall be the Alias for the Multicast Group. S_ID in all frames shall

be the N_Port Identifier of the Sequence Initiator.

- c) The Fabric shall not alter the frame in any way. The Fabric shall simply replicate each frame to every group member.
- d) Sequence Initiative shall not be transferred.
- e) If any group member is not powered on nor able to receive the frame for any other reason, the Fabric Controller shall not re-transmit the frames.
- f) All multicast frames shall be routed in Class 3.

31.4 Broadcast

Broadcast is considered a simplification of multicast. No explicit registration or de-registration is required. Hex 'FFFFFF' is the Well-known address for Broadcast which may be recognized by an N_Port.

NOTE – The Fabric may try to send to all possible N_Ports. However, the Fabric may not be able to deliver to all N_Ports for any number of reasons such as Class mismatch and N_Port not powered on.

The Broadcast Service Parameters shall be defined. All N_Ports that support the Broadcast shall support the Broadcast Service Parameters.

NOTE – The Broadcast Service Parameters shall be the least common denominator for all N_Ports. Normally the Broadcast Service Parameters may correspond to the default parameters.

31.5 Moviecast

Moviecast is an inherent feature of Multicast. An example for Class 3 Multicast: if a source N_Port is multicasting a movie to an Alias Group, another N_Port may join this Alias Group “in progress”. That is, after the registration procedure is complete, the Fabric will start routing frames to the new N_Port. This is possible with Class 3 Multicast since a multicast group can be destination initiated. For a Class 6 Multicast the multicast group is source initiated and does not provide the direct capability for an N_Port to join a Multicast group “in progress”. If intermix is supported an N_Port could request inclusion in a multicast group using a Class 2 or Class 3 frame, supporting an indirect destination initiated multicast group.

31.6 Other

Other forms of multicast are available in topology specific configurations. For examples, see FC-AL for a description of Selective Replicate to perform dynamic multicasting.

dpANS X3.xxx-199x

32 Aliases

No enhancements from FC-PH or FC-PH-2.

33 Dedicated Simplex

No enhancements from FC-PH or FC-PH-2.

34 Class 4- Fractional

No enhancements from FC-PH or FC-PH-2.

35 Camp-On

No enhancements from FC-PH or FC-PH-2.

36 Stacked Connect Request

No enhancements from FC-PH or FC-PH-2.

37 Buffered Class 1 Service

No enhancements from FC-PH or FC-PH-2.

38 Data Compression

No enhancements from FC-PH or FC-PH-2.

39 Clock synchronization service

39.1 Introduction

39.1.1 Applicability

Conventional network technologies utilize clock distribution protocols (e.g. Network Time Protocol) which synchronize the computer's time-of-day clock. Such protocols typically provide clock synchronization accuracies on the order of a few millisecond with highly tuned versions producing accuracies on the order of 50 microseconds.

The synchronization that naturally occurs between transmitters and receivers in a Fibre Channel fabric offers a highly accurate reference for maintaining clock synchronization. If all delays are accounted, accuracies on the order of a few nanosecond become practical. The protocols defined in this clause allow clocks located within N_Ports to be synchronized to nanosecond accuracies.

39.1.2 Function

Clock Synchronization over Fibre Channel is attained by having a Clock Synchronization Server exchange clock synchronization symbols with Clients on a periodic basis determined by its reference clock. (Clock synchronization symbols can be either primitive sequences or ELS.) The Server can be either built into a fabric servicing multiple F_Ports or an independent node servicing one or more N_Ports. The Client can be either an N_Port or a F_Port (when synchronizing other sub-fabrics). Embedded within each clock synchronization symbol is a delay field (measured in clock ticks) for use in the calculation of the one-way propagation delay from the Server port's transmitter to the Client port's receiver.

NOTE – The round-trip propagation delay is used to compute the one-way propagation delay. For best accuracies, the transmit and receive paths between Server's port and the Client port must be equal in length.

When all of the Clients are requested with the Server, they will themselves be synchronized. By tagging data with the current value of their synchronization clock, one client can accurately exchange time sensitive data with another client.

39.2 Communications Model

Figure 114 illustrates the clock synchronization protocol that occurs between the Server and Client port in order for their respective clocks to be synchronized. Periodically the Server's reference clock will generate a synchronization event (t_1). The synchronization event will cause the exchange of clock synchronization request/accept symbols with one or more Clients. (The period of the synchronization event is controlled by the Server.) Embedded within the clock synchronization symbols is the necessary data to compute the delays between the sender and receiver.

Figure 114 – Clock Synchronization Model

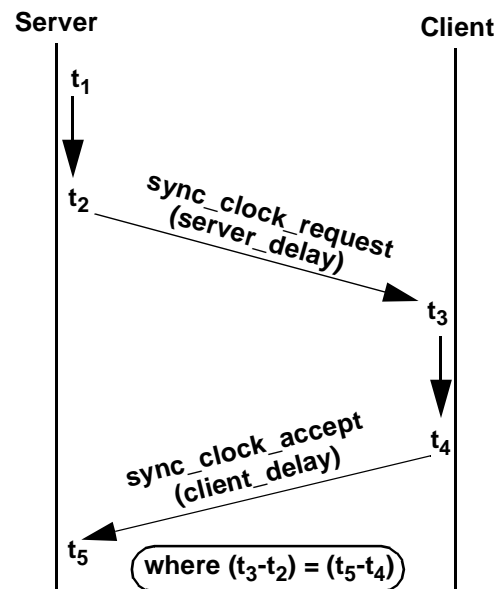

The synchronization event (t_1) eventually results in the transmission of a clock synchronization request symbol to the Client port at time (t_2). Initially, the delay between the synchronization event and when the synchronization event is actually sent ($t_2 - t_1$) is embedded into the delay field of the synchronization symbol (server_delay).

When the Client port receives a clock synchronization request symbol (t_3), it sets its synchronization clock to the value embedded in the delay field of the request symbol ($t_2 - t_1$). It then initiates a clock synchronization accept symbol to the Server (t_4). Embedded in the clock synchronization accept symbol (client_delay) is the delay from when the request symbol was re-

ceived to when the clock synchronization accept symbol is returned ($t_4 - t_3$).

When the Server's port receives the clock synchronization accept symbol from the Client port, it takes the difference ($t_5 - t_2$) between when it sent the clock synchronization symbol (t_2) and when it received the accept (t_5). The Server then computes the total propagation delay ($(t_5 - t_4) - (t_3 - t_2)$) by subtracting the accept delay ($t_4 - t_3$) from ($t_5 - t_2$). The one way propagation delay ($t_3 - t_2$) is then computed by dividing the total propagation time by two (assuming the transmit and receive propagation delays are equal).

The above process is then repeated. On subsequent synchronization events, the Server adds the one-way propagation delay ($t_3 - t_2$) to the delay between the synchronization event and request transmission ($t_2 - t_1$). The resulting embedded delay is the difference between the Client's synchronization clock and Server's synchronization clock ($t_3 - t_1$). By setting its synchronization clock to the value embedded within the clock synchronization request symbol ($t_3 - t_1$), the Client's clock will be synchronized to the Server's clock.

NOTE – From this point on, as long as the Server's transmitter port is connected to the Client's receiver port, the synchronization clocks in the client and server should be synchronized.

39.3 Requirements

The Clock Synchronization Server shall have a clock reference that operates at the speed of the N_Ports being served. The Server shall provide clock synchronization service to one or more Client Ports. Each Client/Server pair must operate with common speeds and classes of service. (The Clients themselves can operate at different speeds and classes of service.) The Server shall send a clock synchronization request symbol on a periodic basis to all Clients being served. The Client port being synchronized shall respond by returning a clock synchronization accept symbol.

Clients can determine the synchronization period by sending an Extended Link Service request to the Server. The synchronization count (sync count) in the Accept Payload (see 39.4.3.1) indicates the synchronization period. The synchronization count is measured in transceiver clock ticks. Clients operating at different speeds will have different synchronization counts.

The Server shall increment a 32-bit reference clock register (reference_clock) at the rate of the clock reference. The reference clock is used to determine the synchronization period for all Clients (sync_count).

The Server's clock reference shall also be used as a reference for all N_Port transmitters being serviced. Each of these N_Ports shall have a 28-bit delay register (server(n)_delay) which increments at the rate of the port's transmitter. The Server shall also have a 28-bit register for each Client to save the computed propagation delay (propagation(n)_delay).

The Clients shall have a set of registers including a 32-bit register for the synchronization clock (client_clock) and a 28-bit register for Client delays (client_delay) both incremented at the rate of the Client port's receiver. Clients shall also have a 32-bit register with their synchronization count (sync(n)_count).

39.3.1 Server Rules

The following statements illustrate the Server's reference clock and synchronization clock logic:

```
if server's clock reference ticks then
    reference_clock = reference_clock + 1
    if reference_clock = sync_count then (t1)
        server(n)_sync = true
        server(n)_delay = 0
```

```
if N_Port (n)'s transmitter ticks
    server(n)_delay = server(n)_delay + 1
```

The following logic statements illustrate the clock synchronization protocol for a Server. These statements shall apply for all (n) Clients:

```
if (server(n)_sync is true) and (port(n) is idle)
    then (t2)
        server(n)_sync = false
        send_symbol (sc_request,
            server(n)_delay + propagation(n)_delay)
        server(n)_delay = 0
```

```
if receive_symbol (symbol, symbol_data) then
    if (symbol = sc_accept) then (t5)
        client_delay = symbol_data
        propagation(n)_delay =
            (server(n)_delay - client_delay)/2
```

39.3.2 Client Rules

The following statements illustrate the Client's clock synchronization logic:

```

if client's receiver clock ticks then
  client_clock = client_clock + 1
  client_delay = client_delay + 1
  if client_clock = sync(n)_count then
    client_clock = 0

```

The following logic statements illustrate the clock synchronization protocol for a Client:

```

if receive_symbol (symbol, symbol_data) then
  if (symbol is sc_request) then (t3)
    client_clock = symbol_data
    client_delay = 0
    client_sync = true

if (client_sync is true) and (port is idle) then (t4)
  client_sync = false
  send_symbol (sc_accept, client_delay)

```

39.4 Clock Synchronization Control

Servicing of a Client port's synchronization clock is controlled through protocols containing a set of request/reply IUs supported by the Server. These requests and replies use FC-PH constructs as defined in the following sections.

39.4.1 Use of FC-PH Constructs

39.4.1.1 Login/Logout

Before performing any clock synchronization operations, a Client port shall perform F_Port Login followed by N_Port Login with the Clock Synchronization Server. When the Client port has no further operations pending, it shall perform N_Port Logout with the Server.

39.4.1.1.1 Initiator Capability

To the Initiator Control Flags (D) specified in FC-PH 23.6.8.3, additional flags are specified in FC-PH-2 (see 23.6.8.3).

The clock synchronozation capability is indicated by the Sequence Initiator (Clock Synchronization Server) during N_Port Login in word 0, bit 4 of N_Port Class service parameters under Initiator Control.

39.4.1.1.2 Recipient Capability

To the Recipient Control Flags (D) specified in FC-PH 23.6.8.4, additional flags are specified in FC-PH-2 (see 23.6.8.4).

The clock synchronozation capability is indicated by the Sequence Recipient (Clock Synchronization Server) during N_Port Login in word 0,

bit 19 of N_Port Class service parameters under Recipient Control.

39.4.1.2 Exchanges

Clock synchronization Exchanges shall be used in a bidirectional manner. That is, clock synchronization Service request IUs and accept IUs shall be transferred on the same Exchange, via the passing of Sequence initiative.

39.4.1.3 Information Units

The Information Unit construct defines the information transferred as a single Fibre Channel Sequence for clock synchronization requests and replies. A single Information Unit contains either a clock synchronization request or a reply. All communication occurs through the Exchange of Information Units. This clause describes both the data which are transparent to FC-PH-3 and those control parameters which are required by FC-PH-3.

39.4.1.4 Common Required FC Parameters

Class of Service

The Server shall support all Classes of Service supported by the Fabric Region to which it is attached. See FC-SW for a discussion of Regions. An Client port may communicate with the Server using any desired Class.

If the Client port or the Server's port uses Class 3 to communicate, it shall provide the Sequence_Tag on the FC_PH service interface. Any Sequence_Tag provided on a given IU shall not be reused on a subsequent IU associated with the same Exchange until either of the following conditions exists:

- R_A_TOV has expired since the Client port or the Server's port has determined that the IU has been transmitted by the FC-2.
- The Client port or the Server's port receives a accept to the transmitted IU from the receiver of the IU.

R_CTL Routing Bits

Routing bits of the R_CTL field shall indicate FC-4 Device Data.

Information Category

All Request IUs shall specify Unsolicited Control. All Accept IUs shall specify Solicited Control.

Sequence Initiative

Sequence Initiative shall be transferred after the transmission of the Request IU, to allow the return of the associated Reply IU (FS_ACC or FS_RJT) on the same Exchange. If Sequence Initiative is not passed on the Request IU, The Recipient shall abort the Exchange.

Destination ID (D_ID)

This parameter shall identify the destination address identifier (hex 'FFFFF6' if the well known address for the clock synchronization service is being used) of the IU.

Source ID (S_ID)

This parameter shall identify the source address identifier of the IU.

Type

All clock synchronization IUs shall specify the Fibre Channel Services TYPE (b'0010 0000').

Error Policy

All error policies, with the exception of Process Policy, are permitted.

39.4.1.5 Common Optional FC Parameters

Expiration/Security Header

The use of this parameter is beyond the scope of this document and is both implementation and system dependent.

Network Header

The use of this parameter is beyond the scope of this document and is both implementation and system dependent.

Association Header

The use of this parameter is beyond the scope of this document and is both implementation and system dependent.

Device Header

The Device Header shall not be used.

39.4.1.6 CT_HDR

The CT_HDR, as defined in FC-GS, shall be supported by the Server. That is, all requests and replies shall contain the CT_HDR. Following is a description of the usage of the various CT_HDR fields.

Revision

This field shall be set to hex '01'.

IN_ID

This field shall be ignored by the Server.

FCS_Type

This field shall be set to hex 'F6'.

Options

This field shall be set to hex '00'.

Application Information Unit

This field shall contain the payload of the a single request or reply.

39.4.2 Clock Control Request

A clock synchronization Client (Sequence Initiator) shall transmit a clock synchronization Request to solicit the Server to perform a control function. If the request is transmitted without the transfer of Sequence Initiative, the responding port shall abort the Exchange and not perform the Request. The clock synchronization Protocol is composed of a clock synchronization Request, followed by a reply, on the same Exchange.

The clock synchronization control request provides the means to enable and disable the clock synchronization service to the Clock Synchronization Client. For the above Request, if an FS_RJT is generated, it shall specify a Reason Code of "Unable to perform command request", unless otherwise indicated. The Reason Code Explanation shall indicate the specific reason for the FS_RJT.

39.4.3 Clock Control Link Service

In order for the clock synchronization service to be established, a Client port, as the Exchange Originator, shall send a FC-4 link service request to the Server. The accept to the request shall indicate the period at which the Client's clock will be synchronized.

39.4.3.1 Clock Control (CSS_CC)

The clock control sequence shall be used by a Client port to determine the clock synchronization services provided by the Server and to control the synchronization clock. The format of the request payload is shown in table 167.

Table 167 – CSS_CC Payload

Item	Size (Bytes)
hex '01000000'	4
command	4

command: This field controls clock synchronization service to the Client. A value of zero (0) indicates the Server shall disable clock synchronization off; a value of one (1) indicates that the Server shall enable clock synchronization using primitive sequences; a value of two (2) indicates that the Server shall enable clock synchronization using ELS sequences; and a value of three (3) indicates the Server shall report its current state.

Fibre Channel service reject (FS_RJT) signifies rejection of the CSS_CC command.

Fibre Channel service accept (FS_ACC) signifies the clock synchronization service has transmitted the clock synchronization information. The format of the accept payload is shown in table 168.

Table 168 – CSS_CC Accept Payload

Field	Size (Bytes)
hex '02000000'	4
synchronization_count	4
state	2
capability	2

synchronization_count: This field is an integer value which defines the number of synchronization clock ticks in millions ($\times 10^6$) between clock synchronization request symbols.

state: This field reports the current clock synchronization state. A value of zero (0) indicates clock synchronization is disabled; a value of one (1) indicates that clock synchronization is enabled using primitive sequences; and a value of

two (2) indicates that clock synchronization is enabled using ELS sequences.

capability: This field reports the clock synchronization capability of the Server. A value of zero (0) indicates the Server supports primitive sequences; a value of one (2) indicates the Server supports ELS primitive sequences; and a value of three (3) indicates support for both.

39.5 Synchronize Clock Request

Either a series of Primitive Signals or ELS service can be used as clock synchronization symbols. Primitive Signals can only occur between frames. Whether ELS or Primitive Signals are being used, synchronize clock symbols must be delayed if the Server or Client port is in the process of transmitting a frame.

NOTE – Highest clock synchronization accuracies occur when clock synchronization primitives are used with Class 1 service and a fabric based Server whose transmitters are referenced to a common clock source.

39.5.1 Primitive Signal Service

Primitive Signals can be used to issue clock synchronization requests and accepts. When the Server's port is connected to the Client port over a point-to-point connection, the use of clock synchronization Primitive Signals can provide higher clock accuracies than are possible with ELS sequences.

39.5.1.1 Terms

The clock synchronization signals for the clock synchronization Primitive Signals consist of the following ordered sets:

SYNx - K28.5, D31.3, CS_X, CS_X'
 SYNy - K28.5, D31.5, CS_Y, CS_Y'
 SYNz - K28.5, D31.6, CS_Z, CS_Z'

The 14-bit value (hex) contained within a clock synchronization signal (x, y, or z) is the concatenation of two 7-bit hexadecimal values (X and X'; Y and Y'; Z and Z' respectively). As defined in Annex K of FC-AL, each 7-bit value has an equivalent neutral disparity Data Character as illustrated in table 169.

Table 169 – Data Character Translation

Value (hex)	Data Character	Value (hex)	Data Character
X	CS_X	X'	CS_X'
Y	CS_Y	Y'	CS_Y'
Z	CS_Z	Z'	CS_Z'

39.5.1.2 Synchronize Clock Request

The synchronize clock request sequence consists of the following primitive signals: (2) Idles; (1) SYNx; (1) SYNy; and (2) Idles.

The concatenation of the binary data fields from the synchronize clock signals (SYNx and SYNy) produce a 28-bit field (xy) which contains the binary value of the Server port's server_delay (see Figure 114).

39.5.1.3 Synchronize Clock Accept

The synchronize clock accept sequence consists of the following primitive signals: (2) Idles; (1) SYNx; (1) SYNz; and (2) Idles.

The concatenation of the binary data fields from the synchronize clock signals (SYNx and SYNz) produce a 28-bit field (xz) which contains the binary value of the Client port's client_delay (see Figure 114).

39.5.1.4 Primitive Signal Insertion

When sending a synchronize clock request symbol, the Server will use the synchronize clock request sequence to substitute the sequence of idles that normally occurs between frames. Likewise when sending a synchronize clock accept symbol, the Client port will use the synchronize clock accept sequence to substitute the sequence of idles.

39.5.2 ELS Service

When using ELS service, The Server, as the Exchange Originator, shall issue Synchronize Clock Requests with the use of FC_PH constructs. With the exception of the Source and Destination identifiers described below, subclause 39.4.1 describes the use of FC_PH constructs.

Destination ID (D_ID)

This parameter shall identify the destination address identifier of the IU for the Client port being synchronized.

Source ID (S_ID)

This parameter shall identify the source address identifier of the IU (hex 'FFFFF6' if the well known address for the clock synchronization Server is being used).

The Server (Sequence Initiator) shall transmit a clock synchronization Request to solicit a participating clock synchronization port to perform a service function. If the request is transmitted without the transfer of Sequence Initiative, the responding port shall abort the Exchange and not perform the Request. The clock synchronization Protocol is composed of a clock synchronization Request, followed by a reply, on the same Exchange.

The Synchronize Clock request provides the means for the Server to synchronize clock synchronization Clients. For the above Request, if an FS_RJT is generated, it shall specify a Reason Code of "Unable to perform command request", unless otherwise indicated. The Reason Code Explanation shall indicate the specific reason for the FS_RJT.

39.5.2.1 Synchronize Clock Link Service

The Server shall synchronize the Client port's clock at a rate that is no greater than the indicated synchronization_count. Clock synchronization events are generated periodically by the Server. The Client can anticipate the synchronization ELSs at a rate no greater than that indicated in the synchronization count.

39.5.2.2 Synchronize Clock (CSS_SC)

The synchronize clock command shall be issued by the Server to synchronize the clock of the Client port. The format of the request payload is shown in table 170.

Table 170 – CSS_SC Payload

Item	Size (Bytes)
hex '03000000'	4
server_delay	4

server_delay: The unsigned sum of: (1) the number of clock ticks between when the clock synchronization event occurred and when the ELS is transmitted; (2) the number of clock ticks for the one-way propagation delay from the Server to the Client port.

Fibre Channel service reject (FS_RJT) signifies rejection of the CSS_SC command.

Fibre Channel accept (FS_ACC) signals a reply from the Client port being synchronized was transmitted with synchronization information to the clock synchronization Server. The format of the accept payload is shown in table 171.

Table 171 – CSS_SC Accept Payload

Field	Size (Bytes)
hex '04000000'	4
client_delay	4

client_delay: The unsigned number of clock ticks that occurred between when the Client port received the clock synchronization request and when the Client port transmitted the clock synchronization accept.

40 Data Encryption

This clause describes and formally defines the data encryption method and format. The encryption algorithm should be designed for fast bulk encryption. However, a specific algorithm is beyond the scope of this document (see Annex A of FC-GS-2). FC-GS-2 (Security key distribution service) defines the mechanism by which encryption keys with different lengths are distributed. The encryption algorithm should be a variable-key-size cipher function which supports multiple key lengths if export versions of products is required.

40.1 Introduction

The Data Encryption option can be invoked by the initiator on a per Information Category basis within a Sequence, immediately preceding segmentation to frame Payloads. Decryption should be performed immediately following Information Category reassembly.

40.2 N_Port Login

The Sequence Initiator's capability to perform data encryption and the Sequence Recipient's capability to perform decryption are determined during N_Port login.

Only if both Sequence Initiator and the Sequence Recipient support the capability can they perform the function.

40.2.1 Initiator Capability

To the Initiator Control Flags (D) specified in FC-PH 23.6.8.3, additional flags are specified in FC-PH-2 (see 23.6.8.3).

The data encryption capability is indicated by the Sequence Initiator during N_Port Login in word 0, bit 5 of N_Port Class service Parameters under Initiator Control.

40.2.2 Recipient Capability

To the Recipient Control Flags (D) specified in FC-PH 23.6.8.4, additional flags are specified in FC-PH-2 (see 23.6.8.4).

The data encryption capability is indicated by the Sequence Recipient during N_Port Login in word 1, bit 20 of N_Port Class service Parameters under Recipient Control.

40.2.3 F_CTL

Data encryption status of an Information Category shall be indicated by the Sequence Initiator to the Sequence Recipient by means of F_CTL bit 10 (see 18.5)

40.3 Applicability

Frame level encryption is applicable to all Classes of service. Data encryption status (F_CTL bit 10) is meaningful in all Data frames of an Information Category.

NOTE – F_CTL bit is defined to be meaningful in all data frames to ensure that the Sequence Recipient recognizes encrypted data with RO usage and out-of-order frame delivery.

40.4 Decryption

The Sequence Recipient shall decrypt data on a per Information Category basis, using Information Category bits of R_CTL and the SEQ_ID of the Sequence to which the Information Category belongs.

Since the Data encryption is performed on a per Information Category basis (not on frame by frame basis), the RO shall not be used with Data encryption. If the Sequence Recipient uses RO and transmits compressed data, the Sequence Recipient shall ignore the RO and decrypt the data for the entire Information Category.

Annex A
(informative)

No enhancements to X3.230-1994 (FC-PH) annex A.

Annex B
(informative)

No enhancements to X3.230-1994 (FC-PH) annex B.

Annex C
(informative)

No enhancements to X3.230-1994 (FC-PH) annex C.

Annex D
(informative)

No enhancements to X3.230-1994 (FC-PH) annex D.

Annex E
(informative)

No enhancements to X3.230-1994 (FC-PH) annex E.

Annex F (informative)

Electrical cable interface implementation examples

NOTE – The cable descriptions listed in this annex replace the cable descriptions present in the equivalent annex in ANSI X3.230-1994. All other portions of the ANSI X3.230 annex remain in effect.

F.1 Example of LV (long-video) coaxial cable characteristics

This large diameter style of coax is capable of relatively long distance transmission due to its low attenuation. Electrical and mechanical characteristics of a cable meeting the requirements of LV links is listed in table F.1. This cable is equivalent to a type-1694A version of RG-6/U.

Table F.1 – Typical characteristics of LV-type coaxial cable

Category Electrical	Impedance see 9.1.1	Capacitance 53,1 pF/m nom.	Attenuation see 9.1.1	Velocity 82%
Category Conductor	Material Bare Copper	Size AWG 18	Construction Solid	Outer diameter 1,02 mm nom.
Category Dielectric	Material Foam Polyethylene	Wall thickness 1,78 mm nom.	Dielectric constant 1,50 nom.	Outer diameter 4,57 mm nom.
Category Shield	Material Tin plated Cu braid over foil		Coverage Braid 95% Foil 100%	Outer diameter -----
Category Jacket	Material PVC	Wall thickness -----	Colour -----	Outer diameter 6,99 mm nom.

F.2 Example of plenum-rated LV (long-video) coaxial cable characteristics

This large diameter style of coax is capable of relatively long distance transmission due to its low attenuation. Electrical and mechanical characteristics of a cable meeting the requirements of plenum rated LV links is listed in table F.1. This cable is equivalent to a type-1695A version of RG-6/U.

Table F.2 – Typical characteristics of plenum rated LV-type coaxial cable

Category Electrical	Impedance see 9.1.1Ω	Capacitance 53,1 pF/m nom.	Attenuation see 9.1.1	Velocity 83%
Category Conductor	Material Bare Copper	Size AWG 18	Construction Solid	Outer diameter 1,02 mm nom.
Category Dielectric	Material Foamed Teflon	Wall thickness 1,65 mm nom.	Dielectric constant 1,50 nom.	Outer diameter 4,32 mm nom.
Category Shield	Material Tin plated Cu braid over foil		Coverage Braid 95% Foil 100%	Outer diameter -----
Category Jacket	Material Chloride-based or Fluorocopolymer	Wall thickness -----	Colour -----	Outer diameter 5,94 mm nom.

F.3 Example of TV (video) coaxial cable characteristics

This intermediate diameter style of coax is capable of medium distance transmission due to its low attenuation. Electrical and mechanical characteristics of a cable meeting the requirements of TV-type links is listed in table F.1. This cable is equivalent to a type-1505A version of RG-59/U.

Table F.3 – Typical characteristics of TV-type coaxial cable

Category Electrical	Impedance see 9.1.2	Capacitance 53,1 pF/m nom.	Attenuation see 9.1.2	Velocity 83%
Category Conductor	Material Bare Copper	Size AWG 20	Construction Solid	Outer diameter 0,81 mm nom.
Category Dielectric	Material Foam Polyethylene	Wall thickness 1,43 mm nom.	Dielectric constant 1,50 nom.	Outer diameter 3,68mm nom.
Category Shield	Material Tin plated Cu braid over foil		Coverage Braid 95% Foil 100%	Outer diameter -----
Category Jacket	Material PVC	Wall thickness -----	Colour -----	Outer diameter 5,97 mm nom.

F.4 Example of plenum-rated TV (video) coaxial cable characteristics

This intermediate diameter style of coax is capable of medium distance transmission due to its low attenuation. Electrical and mechanical characteristics of a cable meeting the requirements of plenum rated LV-type links is listed in table F.1. This cable is equivalent to a type-1506A version of RG-59/U.

Table F.4 – Typical characteristics of plenum rated TV-type coaxial cable

Category Electrical	Impedance see 9.1.2	Capacitance 52,8 pF/m nom.	Attenuation see 9.1.2	Velocity 83%
Category Conductor	Material Bare Copper	Size AWG 20	Construction Solid	Outer diameter 0,81 mm nom.
Category Dielectric	Material Foamed FEP Teflon	Wall thickness 1,31 mm nom.	Dielectric constant 1,50 nom.	Outer diameter 3,68 mm nom.
Category Shield	Material Tin plated Cu braid over foil		Coverage Braid 95% Foil 100%	Outer diameter -----
Category Jacket	Material Chloride-based or Fluorocopolymer	Wall thickness -----	Colour -----	Outer diameter 5,05 mm nom.

F.5 Example of plenum-rated MI (miniature) coaxial cable characteristics

The attenuation of miniature coaxial cable is significantly more lossy than either the LV or TV styles of coax. Its usage is limited to short connections between pieces of equipment. Electrical and mechanical characteristics of a cable meeting the requirements of plenum rated MI-type links is listed in table F.1. This cable is equivalent to a type-83264 version of RG-179.

Table F.5 – Typical characteristics of plenum rated MI-type coaxial cable

Category Electrical	Impedance see 9.1.3	Capacitance 64,0 pF/m nom.	Attenuation see 9.1.3	Velocity 69,5%
Category Conductor	Material Silver coated Copper covered Steel	Size AWG 30	Construction Stranded	Outer diameter 0,30 mm nom.
Category Dielectric	Material Teflon	Wall thickness 0,64 mm nom.	Dielectric constant -----	Outer diameter 3,68 mm nom.
Category Shield	Material Silver coated Cu braid		Coverage Braid 95%	Outer diameter -----
Category Jacket	Material Teflon	Wall thickness -----	Colour -----	Outer diameter 2,54 mm nom.

F.6 Example of STP cable characteristics

This cable should be compatible with existing "Type-1A" and "Type-2A" 150Ω STP cable. Electrical and mechanical characteristics of a cable meeting the requirements of TP links is listed in table F.1. This cable is equivalent to a type-9688 version of Type-1A STP.

Table F.6 – Typical characteristics of TP-type cable

Category Electrical	Impedance see 9.2.1	Capacitance 27,9 pF/m nom.	Attenuation see 9.2.1	Velocity 69,5%
Category Conductor	Material Bare Copper	Size AWG 22	Construction Solid	Outer diameter 0,65 mm nom.
Category Dielectric	Material Foamed Polyethylene	Wall thickness -----	Dielectric constant -----	Outer diameter -----
Category Shield	Material Metalized Foil with tinned Cu braid		Coverage Foil 100% Braid 65%	Outer diameter -----
Category Jacket	Material PVC	Wall thickness -----	Colour Black	Outer diameter 7.5mm x 10.9mm nom.

F.7 Example of TW cable characteristics

This cable should be used in skew sensitive environments, or where overall cable size is a factor. Electrical and mechanical characteristics of a cable meeting the requirements of TW-type links is listed in table F.1.

Table F.7 – Typical characteristics of TW-type cable

Category Electrical	Impedance see 9.2.2	Capacitance -----	Attenuation see 9.2.2	Velocity 83%
Category Conductor	Material Tin or Silver plated Copper	Size 22 AWG	Construction Stranded or solid	Outer diameter -----
Category Dielectric	Material various	Wall thickness -----	Dielectric constant -----	Outer diameter -----
Category Shield	Material Metalized foil and Cu braid		Coverage Foil 100% Braid 85%	Outer diameter -----
Category Jacket	Material various	Wall thickness -----	Colour -----	Outer diameter -----

|

Annex G
(informative)

| No enhancements to X3.230-1994 (FC-PH) annex G.

Annex H
(informative)

| No enhancements to X3.230-1994 (FC-PH) annex H.

Annex I
(informative)

| No enhancements to X3.230-1994 (FC-PH) annex I.

Annex J
(informative)

| No enhancements to X3.230-1994 (FC-PH) annex J.

Annex K
(informative)

| No enhancements to X3.230-1994 (FC-PH) annex K.

Annex L
(informative)

| No enhancements to X3.230-1994 (FC-PH) annex L.

Annex M
(informative)

| No enhancements to X3.230-1994 (FC-PH) annex M.

Annex N
(informative)

| No enhancements to X3.230-1994 (FC-PH) annex N.

Annex O
(informative)

No enhancements to X3.230-1994 (FC-PH) annex O.

Annex P
(informative)

No enhancements to X3.230-1994 (FC-PH) annex P.

Annex Q
(informative)

No enhancements to X3.230-1994 (FC-PH) annex Q.

Annex R
(informative)

No enhancements to X3.230-1994 (FC-PH) annex R.

Annex S (informative)

FC-PH Service Interface

This annex describes changes to the FLOGI and PLOGI service interface.

S.2.3 FABRIC_LOGIN.request

This primitive is used to provide Fabric Login parameters and to request a login with the Fabric, if necessary.

S.2.3.1 Semantics of the Primitive

FABRIC_LOGIN.request

(My_ID,
Local_N_Port,
My_Fabric_Service_Parameters)

My_ID will specify the S_ID to be used in the Sequence that delivers the Fabric Login. See 23.3.1 for the usage of the S_ID in Fabric Login.

Local_N_Port will specify the local N_Port which is to issue the FLOGI.

My_Fabric_Service_Parameters will optionally specify the parameters to be used in the payload of the Fabric Login.

S.2.3.2 When Generated

A level above FC-PH will generate this primitive to provide operating parameters to FC-PH and to request a Fabric Login.

S.2.3.3 Effect of Receipt

If the N_Port specified by My_ID is not currently logged into the Fabric, the receipt of this primitive will cause FC-PH to attempt Link Initialization (see 16.6.2) if the Link is not active and to transmit a Fabric Login Sequence with Class as specified by 23.3.3.

If the N_Port specified by My_ID is currently logged into the Fabric, the receipt of this primitive will cause FC-PH to return the current Fabric Service Parameters, via the FABRIC_LOGIN.confirmation. Link Initialization is not performed and a Fabric Login Sequence is not transmitted. However, the N_Port may issue an FDISC ELS to obtain the most current Fabric Login parameters.

S.2.4 FABRIC_LOGIN.indication

No change from FC-PH.

S.2.5 FABRIC_LOGIN.confirmation

This primitive will provide an appropriate response to the FABRIC_LOGIN.request primitive signifying the success of the primitive and, if a Fabric is present, will provide the Service Parameters returned by the Fabric.

S.2.5.1 Semantics of the Primitive

FABRIC_LOGIN.confirmation

(My_ID,
Local_N_Port,
Request_Status,
Reject_Reason,
Fabric_Status,
Other_Port_Fabric_Service_Parameters)

My_ID will reflect the D_ID returned in the Fabric Login Accept Frame.

Local_N_Port will indicate the local N_Port which issued the FLOGI.

Request_Status will indicate status as one of the following:

- Successful - Fabric Login completed.
- Unsuccessful - Sequence was not delivered completely due to reason other than reject.
- Rejected_Request - The Request was not sent by the Initiator due to the specified Reject_Reason.
- Rejected_by_Fabric - Reject frame received from Fabric.
- Rejected_by_N_Port - Reject frame received from N_Port.
- Rejected_by_Link_Services - Link Services Reject frame received from N_Port.

When the Request_Status is Rejected_Request, Rejected_by_Fabric, or Rejected_by_N_

Port, the Reject_Reason will indicate one of the Reject reason codes given in Table 55.

The Fabric_Status will indicate status as one of the following:

- isolated - Link is not connected.
- no_fabric - N_Port is connected point-to-point with another N_Port.
- fabric - N_Port is connected to a Fabric.

Other_Port_Fabric_Service_Parameters will optionally specify the parameters to be used for the F_Port in the operation of a Fabric when a Fabric is present as indicated by Fabric_Status, or will optionally specify the parameters to be used for the other N_Port when no_fabric is indicated by Fabric_Status.

S.2.5.2 When Generated

S.2.5.3 This primitive is generated upon completion of a Fabric Login attempt.

S.2.5.4 Effect of Receipt

The effect of receipt of this primitive by the FC-4 entity is unspecified.

S.2.6 IMPLICIT_FABRIC_LOGIN.request

No change from FC-PH.

S.2.7 N_Port Login Primitive Flows

No change from FC-PH.

S.2.8 N_Port Login Service Parameters

No change from FC-PH.

S.2.9 N_PORT_LOGIN.request

This primitive is used to provide N_Port Login parameters and to request a login with another N_Port, if necessary.

S.2.9.3 Effect of Receipt

If the N_Port specified by My_ID is not currently logged into the N_Port specified by Other_ID, the receipt of this primitive will cause FC-PH to transmit an N_Port Login Sequence with a Class as specified by 23.4.3. The count of the number of Login requests for the specified N_Port pair is set to 1.

If the N_Port specified by My_ID is currently logged into the N_Port specified by Other_ID, the receipt of this primitive will cause FC-PH to

return the current N_Port Service Parameters for the N_Port specified by Other_ID, via the N_PORT_LOGIN.confirmation. An N_Port Login Sequence is not transmitted, but a count of the number of Login requests for the specified N_Port pair is updated. However, the N_Port may issue an a PDISC ELS to obtain the most current N_Port Login parameters.

S.2.14 N_PORT_LOGOUT.request

This primitive is used to request that a Login be terminated with the specified N_Port.

S.2.14.3 Effect of Receipt

Receipt of this primitive will cause FC-PH to decrement the count of the number of Login requests for the specified N_Port pair.

If the count of Login requests for the specified N_Port pair is not yet zero, FC-PH does not generate a Logout Sequence.

If the count of Login requests for the specified N_Port pair is now zero, receipt of this primitive will also cause FC-PH to generate a Logout Sequence.

Annex T
(informative)

| No enhancements to X3.230-1994 (FC-PH) annex T.

Annex U
(informative)

| No enhancements to X3.230-1994 (FC-PH) annex U.

Annex V
(informative)

| No enhancements to X3.230-1994 (FC-PH) annex V.

Annex W
(informative)

No enhancements to X3.230-1994 (FC-PH) annex W.

Annex X
(informative)

| No enhancements to X3.xxx-1995 (FC-PH-2) annex T.

Annex Y
(informative)

| No enhancements to X3.xxx-1995 (FC-PH-2) annex U.

Annex Z
(informative)

| No enhancements to X3.xxx-1995 (FC-PH-2) annex V.

Annex AA
(informative)

No enhancements to X3.xxx-1995 (FC-PH-2) annex AA.

Annex AB
(informative)

No enhancements to X3.xxx-1995 (FC-PH-2) annex AB.

Annex AC (Informative)

A Real Time Loop Based Fibre Channel Topology

AC.1 Scope

This annex describes a data distribution architecture based on the use of Fibre Channel constructs aimed at real time applications where a known worst case amount of guaranteed bandwidth is needed. These applications include the distribution of real time audio and video. Though the architecture is loop based, it provides higher layer protocol support to act as a crosspoint switch as well. The loop at each node also provides a point to point interface which makes the architecture expandable into a

mesh like structure. From a Fibre Channel perspective, with minimal exceptions noted herein, the architecture design is compliant with FC-PH rev 4.3. Compliance to FC-PH-3 is used to cover exceptions to FC-PH rev 4.3 necessary to support real time operation. No primitives or link services beyond those defined in FC-PH rev 4.3 are necessary for its implementation. In detail this annex defines the overall topology, a new port type, the real time loop (RTL) port, the specific Fibre Channel services which are used, and the layers of protocol above Fibre Channel needed to define the architecture.

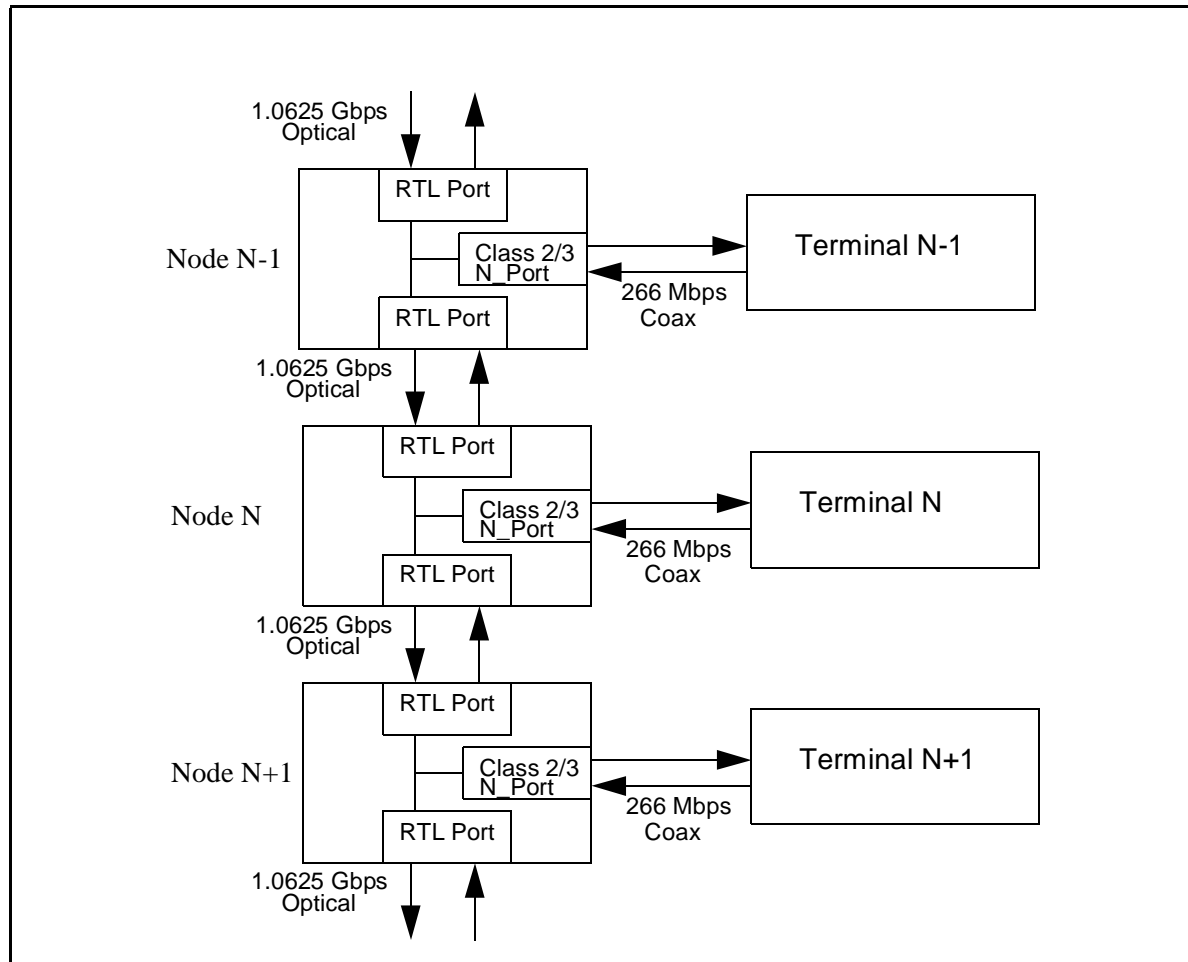

Figure 112 – Real Time Loop Topology

AC.2 General Description

The distribution system is based on a ring topology. The ring structure consists of a set of nodes tied together in a point to point configuration as shown in figure 112. Within each node are two Real Time Loop (RTL) Ports which support Fibre Channel class 3 communications and an N_Port which supports class 2 and 3 communication. The distribution protocol uses a slotted or "register insertion" algorithm. The point to point class 3 interconnects conform to the ANSI X3.230 Fibre Channel standard. Each RTL port communicates with its neighbor RTL port using a full speed (1.0625 Gbaud) optical (100-M5-SL-I) bi-directional path to its neighbor node which operates in a full duplex mode.

The N_Port to Terminal interconnect shown in figure 112 represents a full duplex point to point known as a Local Node Interface. This link represents a quarter speed coaxial (265.625 Mbaud 25-TV-EL-S) access point to the ring's data structures. Optics are optional at this interface.

As shown in figure 114, the Fibre Channel FC2 layer is a Time Division Multiplexed (TDM) win-

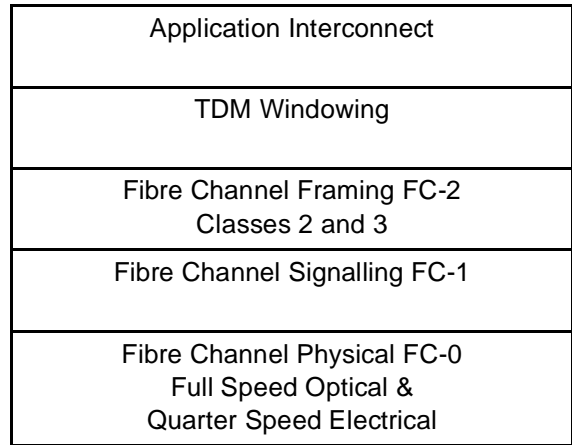

Figure 113 – Real Time Protocol Stack

dowing protocol which provides for synchronous data delivery. The system designer is given access to this protocol structure so that bandwidth can be allocated based on application requirements. By programming these windows, the user can allocate any amount of bandwidth to any type of data, and to any network terminal. The loop architecture with the synchronous windowing technique built on top of Fibre Channel is here after referred to as the Fibre Channel Real Time Loop (FC-RTL) topology.

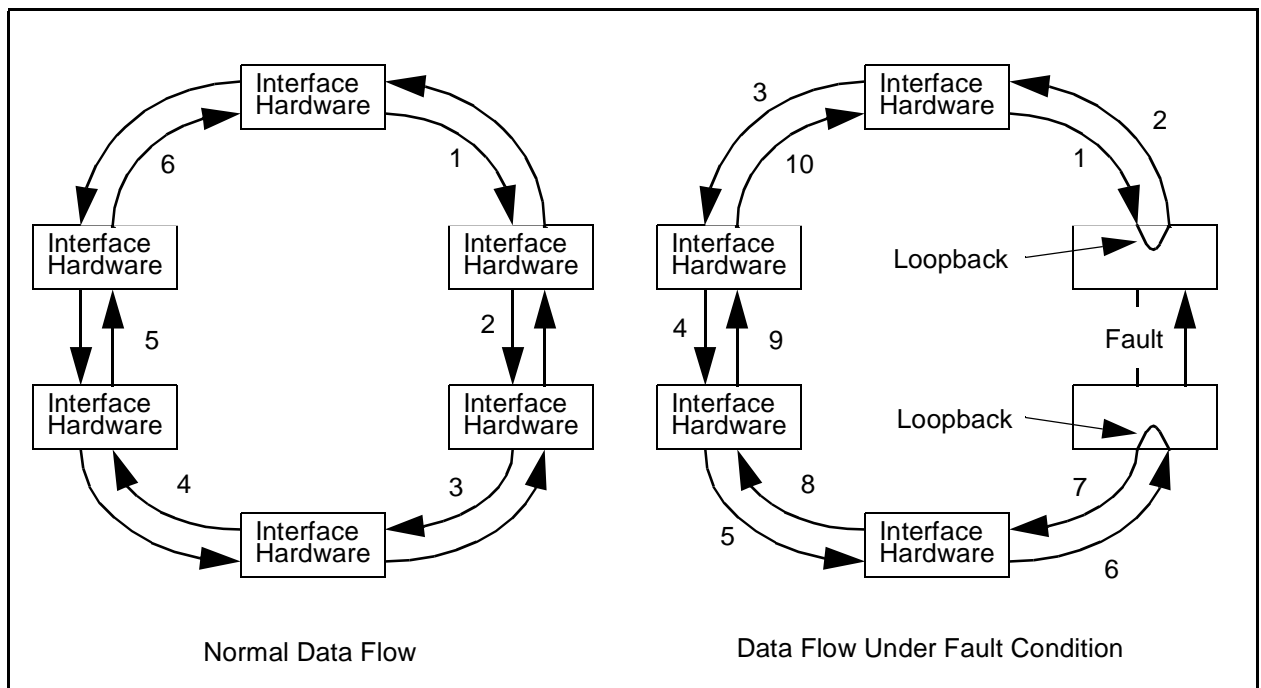

Figure 114 – Failure Detect and Re-routing

This layer also provides the FC-RTL with support for a counter-rotation feature. During normal error free operation, data flows primarily in one direction with the return path used for flow control. When an error occurs either through the result of a link failure or the failure of a node, neighboring nodes can autonomously detect the failure and reroute the data around the error as shown in figure 114. In this way the system provides recovery from single point failures without the need for expensive backup or redundant rings.

In addition, the TDM layer provides support for allocating bandwidth (that is not being used for synchronous communications) for asynchronous non-real time control type traffic. The built in asynchronous support is used for determining mastership, for system synchronization, and for error recovery.

AC.2.1 Network Data Flow

Network data flow can be divided into synchronous and asynchronous traffic. The frame based data structure for transmissions is shown in figure 114.

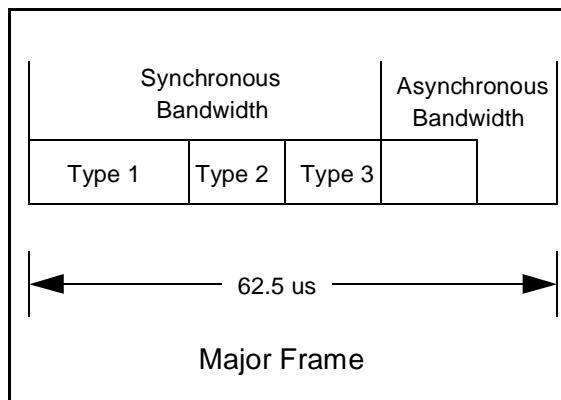

Figure 115 – TDM Window

In this example, the highest rate frame is 16 KHz, and a major frame is a 62.5 us window of data. This window size is programmable with the minimum size determined by RTL port design. Each window is broken down into synchronous and asynchronous bandwidth. The window is then further broken down into minor frame types. For example, Type 1 might be audio, Type 2 might be video, and Type 3 might be control information. These minor frame types consist of a number of 16 bit data words, and are transmitted as one or more Fibre Chan-

nel frames. The minor frame size is programmable and represents the amount of bandwidth that has been assigned to a particular data information type. Thus, if Type 1 was audio and consisted of 2000 words, the bandwidth allocation for audio would be $2000 * 16 \text{ bits} * 16 \text{ KHz}$ or 512 Mbps.

AC.2.1.1 Synchronous Service

To provide for guaranteed data delivery, the network provides a synchronous data frame service. This may be viewed as a set of exchanges/sequences/frames which are initiated by one node, designated as the Master node, according to a predetermined rate schedule. These frames are delivered to each node in succession, and may be used by that node for the purpose of encapsulating data. The receiving node may in effect, capture the frame, modify it, and retransmit it in the corresponding time slot.

To provide for synchronous bandwidth allocation, each data source is allocated a number of channels which it can use to insert information onto the network. These channels are grouped into a set of frame types which are distributed at different rates. As an example, a data source could be allocated 100 16 KHz channels and 100 50 Hz channels. This would be an allocation of 1,605,000 16 bit channels, or 25.68 Mbits/sec of network bandwidth to the data source. The frame types, their sizes, and their rates are all totally programmable. Maximum frame rates and numbers of provided data types are a function of RTL Port design.

AC.2.1.2 Asynchronous Service

Should applications not require 100% use of the network's bandwidth for synchronous service, the remaining bandwidth can be used asynchronously -- whenever it is available.

The asynchronous bandwidth is used only when window space is available after synchronous bandwidth has been allocated. Asynchronous bandwidth can also be used at initialization before synchronous frame transmissions have begun. Note that the network design supports a configuration where the amount of allocated synchronous bandwidth is zero, and therefore allowing 100 % of the bandwidth to be allocated to asynchronous communications. The system does not support

multiple data types in the asynchronous mode. The asynchronous mode is not an optional feature however, as it is required for system initialization and error recovery.

To prevent the transmitting node from capturing the network for an extended time, the RTL port shall be capable of implementing a fairness algorithm while in asynchronous mode. After a prescribed number of successful frame transmissions, the node shall allow sufficient time to permit at least any one of the other nodes on the ring the opportunity to start a frame. In the event of a collision, the node shall implement a delay prior to any re-attempt to capture a transmit opportunity.

AC.2.2 Network Characteristics

AC.2.2.1 Master Node

Data distribution through the network is controlled by a "master node". Each node has the capability of being the master, but only one master is active at a time. Mastership establishment is done at network initialization time through an arbitration algorithm. Upon power up, after a node determines that it is functional, it begins transmitting an asynchronous frame which contains its network address. It continues this until it receives from its upstream node an address which is greater than its own. If this occurs, the master begins transmitting the highest address that it receives. When a node receives its own address, it assumes the mastership role and begins transmitting synchronous frames. Once a node obtains mastership, it retains the role until either it fails or the system is shut down. The network provides automatic master failure detection and recovery to a new master.

The master node is the synchronization point of the network. It resynchronizes frames as they pass through it. The master node is synchronized to an external clock which it uses to determine when to transmit a major frame. It also houses a scheduler which it uses to determine the minor frame types to include in each major frame.

AC.2.2.2 Data Distribution Characteristics

Initially, the window is transmitted by the master as nulls in each channel of each frame type. As each terminal sees this null frame it can source data into its pre-allocated channels as the

frame passes through its "local node". Once the frame which was originated by the master is received back by the master (after having traversed the ring), it is resynchronized by the master. Any data received by the master is inserted into the next frame that it transmits.

Terminals which source data are also responsible for removing it from the network, otherwise it would traverse the ring continuously. This is done when the data source's local node receives back what it has transmitted.

A terminal is aware of which slots of a particular data type have been allocated to it through the use of a data structure known as an "access table". This access table simply consists of a single bit for each data word in each frame type. The state of each bit determines whether or not a node is to make a copy of the data word represented by the bit as it passes through the node. This table is dynamically programmable, and a copy of it is kept at each terminal and at each terminal's local node. Management of these tables is the primary means for creating a crosspoint from a terminal source to a destination. For a terminal to obtain access to a particular channel, it simply makes a request to the table manager (software that currently executes on a CPU board in one of the terminals) who in turn modifies the requesting terminal's access table. These tables can reside in non-volatile memory at power on, so that fixed connections can be made as the network is initialized. The tables are also accessible from the network itself so that they can be read or written to and downloaded if necessary.

Class 3 Fibre Channel functionality is defined as a datagram communication methodology which operates in a "send and forget" manner. This is a connectionless service which does not provide reception acknowledgment or automatic retransmission in response to error detection. This class is used in the ring portion of the system architecture because of the type of data it has been designed to distribute -- high data rate audio and video. Due to the nature of the data itself, real time error recovery in terms of data retransmission is not practical, and the choice of class 3 (which does not provide this service) keeps the interface circuitry complexity to a minimum. Still, class 3 provides buffer to buffer flow control so that data is not lost because of the lack of buffer space at the receiv-

er. The system provides inband signaling and control distribution which requires more robust acknowledgment and error recovery services. Since this is not provided by Fibre Channel itself (in Class 3), it is handled in a upper level protocol shown in figure 114.

Each network node also provides a point to point Fibre Channel interconnect to a network terminal as shown in figure 112. This point to point interface provides Fibre Channel class 2 and 3 communication services. This interface provides an access point to sources and destinations of network information. Class 2 services are offered here so that bridges to other network structures such as LANs, SCSI drives, ATM switches, etc are possible. Thus the ring topology can be considered a local area network with bridges to other local or wide area networks. The node then acts as a gateway between a Fibre Channel real time loop and a Fibre Channel point to point connection.

AC.2.2.3 Network Latency

The real time loop topology has been designed to a top level system requirement of a 2 millisecond loop rotation time. Any data sourced to the network will be received by any other terminal on the network within 2 ms, and the time delta between the reception of the same data for any two terminals is 2 ms. The network guarantees this through its system design regardless of how much traffic is currently on the network. Obviously, this latency is dependent on the number of nodes on the network, and this latency can be exceeded if enough nodes are put onto the network. However simulations of the interface hardware design have shown that with a wormholing approach, a 128 byte Fibre Channel frame can be moved through a node in less that 10 microseconds. With this timing, the latency requirement above can be achieved with a configuration of 2000 nodes. These times are achievable, because, once the system has been initialized, there is no software interaction required for data movement from input RTL port to output RTL port through the node.

AC.2.2.4 Sequence/Exchange Management

When a new window is scheduled on the loop, it may consist of several data types, but will always consist of at least one data type (there are no empty windows). Each window's worth of

each data type scheduled for that window can consist of multiple Fibre Channel frames. This series of Fibre Channel frames are packaged into a Fibre Channel Exchange as defined in FC-PH. Each data type within the window will be given its own exchange. Thus multiple exchanges can be transmitted within a window. However, only one exchange is open at any one time. Within a particular exchange, only one sequence is opened at a time. An RTL_Port can only manage one exchange at a time. Within this one open exchange, the RTL_Port can manage multiple sequences of multiple types of data. Only one sequence can be active at a time, and each frame within a sequence is always of the same type.

An RTL_Port is capable of transmitting and receiving up to 16 different types of information. The transmitted type is identified in the "type" field of the Fibre Channel header. An RTL_Port also applies types to exchanges. A port supports up to four different exchange types, each corresponding to a particular error policy as defined in FC_PH. Each frame transmitted within an exchange of a particular type will be treated with the error policy defined for the exchange.

Furthermore, because the RTL_Port is used in a real time system, it uses the sequence type within an exchange to decide what sequence has transmission priority should a transmission schedule overlap sequence transmission rates.

AC.2.2.5 Use of Flow Control

Since the RTL components of the architecture use class 3 communication, only R_RDY primitives are available for flow control, and these are used at each ring interconnect. Specifically, a RTL port transmits an RDY whenever a buffer becomes available. This is used by the source RTL port to maintain buffer to buffer credit. When the RTL network is used in synchronous mode, all data types and sizes are programmable as are the transmission rates of each type. Since the frame rates and sizes can be determined by the system designer ahead of time, the RTL port buffer space can be designed to support the worst case transmission scenario. Thus in this mode of operation a RTL port can theoretically transmit without waiting for RDYs to indicate buffer availability at the destination. However, each RTL port supports the transmission and reception of RDYs as de-

defined in FC-PH. This is done to support the asynchronous mode of operation, error recovery situations, and to insure specification compliance and interoperability issues.

AC.2.2.6 Error Recovery

AC.2.2.7 Use of Discard Policy

The network design permits the use of Discard Policy for synchronous and asynchronous frames. The use of Discard Policy is as defined in FC-PH rev 4.3.

AC.2.2.8 Use of Process Policy

The network design allows the use of process policy for synchronous frames. It makes no attempt to process data within an invalid Fibre Channel frame, but continues to process subsequent frames within the sequence of which an invalid frame is a part. This permits the use of most of an audio or video sequence in the case where potentially only small portions are lost.

This process policy is defined in FC-PH-3 and is a modification to X3.230 in that it allows the sequence to continue even if the first or last frame of a sequence is lost. In this case, the abort sequence bits in the frame header are valid for each frame in the sequence, not just the first.

Since the interface permits only one concurrent sequence, it can detect that a sequence has ended by the reception of another frame with a different sequence ID. The interface also closes a sequence if E_D_TOV times out before the reception of the last frame of a sequence or the reception of a frame of another sequence.

AC.2.2.9 Acknowledgement

Since the loop interconnects communicate using class 3 services, no acknowledgment is provided by the Fibre Channel interface hardware. Where needed, mainly for in-band control functions, acknowledgment is provided by the Upper Layer Protocol (ULP). Acknowledgment is provided by the point to point interface using class 2 services.

AC.2.2.10 Wormholing

To decrease network latency, frames pass through the two RTL_Ports within a node using

a "wormholing" algorithm. Received frames will be retransmitted by the node without having been fully received and validated. Both the receiving RTL_Port and the transmitting RTL_Port are operational with respect to the optical link simultaneously. Also, multiple nodes can be processing a particular frame of data at the same time. Note that this frame could be altered after it was initiated, so that when multiple nodes are processing the same frame each node may be working on a different payload.

AC.2.2.11 Frame Validation

With wormholing in effect for synchronous service, several nodes can be accessing data from the same frame simultaneously. This means that data is extracted by a node before the frame has been validated, and thus invalid data may be extracted. However, it is not the node that uses the extracted data - it is the terminal. It doesn't matter that the node has extracted bad data as long as it is not sent to the local terminal. In order to prevent this from happening, the node does not send data to its local terminal until the received network frame has been validated.

Note also that wormholing causes a problem on the insertion of data into a frame as well. As a frame is traversing through a node, new data in the node's insertion buffer (sourced by its local terminal) is put into the frame. This happens before the frame is validated as well. Thus good data can be put into an invalid frame. This again is overcome since the destination terminal will not ever see this data. Frames which are determined to be invalid because of an incorrect CRC or an invalid payload by a node are terminated with an EOFi delimiter upon retransmission. Although the downstream node may have extracted data from this invalid frame due to the use of wormholing, it will not transmit the data to its local terminal when it sees the EOFi delimiter. The extracted data, some of which might have been good data, is dropped by the node. Frames with an EOFi end delimiter continue to be propagated by the network nodes until they reach the master node where they are removed.

Frames that are not correctly delimited are removed by the node which detects the incorrect delimiter. These frames do not propagate back to the master node.

AC.2.2.12 External Clocks

As the network was designed to support fully synchronous data distribution, carefully consideration is given to controlling jitter. The network is designed to support the distribution of information such that the phase relationship of data put onto the network and taken off of the network can be maintained. To support this the master node (and its associated backup(s)) are provided external master clocks which are used to synchronize the delivery of windows. The rate of these clocks is a system design parameter. However, for interoperability considerations a standard rate should be chosen. The recommendation here is a 4.096 MHz clock. It is further recommended that the clock source be redundant.

AC.2.2.13 Link Recovery

In the event that the communication channel between two nodes fails, the RTL_Ports which make up the link will continuously attempt to re-establish communication. In this failure scenario, the two nodes go into loopback and network data flows in a counter-rotating manner. Still the RTL_Ports which are now out of the loop will use the link recovery mechanisms defined in FC-PH to repair the loop. Should the link recovery be successful the two nodes will transition out of loopback mode and into normal operation. Note that Login is performed before the healed interconnect can support data flow.

AC.2.2.14 Real Time Support

The network design is intended to support real time applications, and deterministic performance is necessary. With this intent in mind, the propagation delay through a node in the network is a fixed constant number of clock cycles at each node. Each node is expected to maintain an internal clock to within the specified tolerance limits specified for Fibre Channel data transmission. As specified in FC-PH the transmitter is required to provide a minimum of six clock cycles between frames. With a fixed number of clock cycles per node (within the tolerances of the transmission clocks at each node) the frames will maintain their relative time positions. This fixed number of clock cycles is a system design parameter. However, when interoperability is considered the number of clock cycles should be standardized.

AC.2.2.15 Smoothing Algorithm

With this network topology, there exists the eventual certainty of clock mismatch due to clock frequency skew and jitter. Since each node transmitter is attempting to maintain the FC-PH requisite number of six fill characters between frames, the eventual accumulation of clock difference between the receive and transmit clock domains a character (taken to be a fill) will either have to be deleted or inserted. Each node supports a smoothing algorithm to account for the difference in clock domains passing from node to node. Since each node uses a clock that meets the frequency tolerances defined in FC-PH, only fractional clock differences are accumulated on a frame to frame basis.

Each node provides enough elasticity buffering to accommodate input data overflow/underflow that occurs within the lifetime of a frame and will attempt to recover the difference by adjusting the perceived number of fills received.

AC.2.2.16 Frame Addressing

For synchronous frame services, each frame transmitted by any node on the network always contains the master's address as the S_ID and the D_ID. These identification fields within the Fibre Channel frame header can be modified only by the master node. All other nodes simply pass them through. When the master node receives a frame with its D_ID in the header field, it removes the frame from the network. Note that the payload within the frame is not dropped, but is stored locally at the master node. This payload will be inserted into the next scheduled frame of the received type.

For asynchronous frames the S_ID field contains the address of the frame source (which can be any node on the network). The D_ID is the address of the desired destination. Again, when the node sees its address in the D_ID field of an asynchronous frame, it removes the frame from the network. Since there is no re-scheduling of the asynchronous frames, the transmission ends upon frame removal by the destination.

AC.2.2.17 In-Order Delivery

RTL_Ports use an in-order delivery scheme for all synchronous and asynchronous transactions throughout the network in a manner described in FC-PH. All RTL_Ports logon to each other

with the in-order delivery parameter set to "required".

AC.2.2.18 Frame Size

Network frame sizes are system design parameters, and buffer space is a function of RTL_Port design. However, as a minimum the network interface to each local node should provide 31 buffers each sized at a minimum of 512 bytes of data. The interface also should provide buffer space for 31 frame headers of 32 bytes each.

AC.3 System Level Components

AC.3.1 Node Description

As previously defined, a node consists of two RTL_Ports and an N_Port. Each node also provides its own power rather than obtaining power from its local terminal. Autonomous power allows the loop to maintain full functionality should a terminal fail.

AC.3.2 RTL_Port Functionality

At its optical interface with its upstream or downstream Port, an RTL_Port operates as a class 3 N_Port as defined in FC-PH. At its backend parallel electrical interface an RTL_Port communicates with a second RTL_Port and the N_Port within the same node. As a RTL_Port receives data from its upstream neighbor, it uses its access table to determine which parts of the payload (if any) to copy as the frame passes through it. Copied data is made available to the N_Port for transmission to the local terminal. The receiving RTL_Port is also responsible for validating the received frame. Data is not transmitted to the local terminal by the N_Port until the received frame has been validated. The receiving RTL_Port is responsible for invalidating a frame in the manner defined in FC_PH should it detect an error.

The N_Port within the node is responsible for building the new data to be retransmitted by the node. It does so based on data received from its local terminal via its point to point interface. The local terminal has been told previously where in each frame that it can originate data. This knowledge is kept in the access table housed within the local terminal. The N_Port also knows where within each frame it has previously inserted data into the network. In its allocated frame locations where it is sourcing no

new data, the N_Port must insert nulls. This effectively removes data from the network that it has previously sourced.

The second RTL_Port within the node is responsible for packaging the data generated by the N_Port into a Fibre Channel frame and transmitting it to its downstream neighbor. This RTL Port is also responsible for generating the CRC before transmission.

The backend interfaces of both RTL_Ports in conjunction with the backend interface of the N_Port act together to create a fabric like structure. These backend interfaces move data from one N_Port to another N_Port. This might be considered the primary responsibility of a Fibre Channel fabric. One major difference between this functionality and that of a fabric is that data is that data may be modified as it passes through the fabric. Since it is not a FC_PH compliant fabric, it is really performing a ULP function.

AC.3.3 RTL_Port/N_Port Fibre Channel Characteristics

AC.3.3.1 Primitive Signals

All ports within a node support all FC-PH rev 4.3 primitive signals and requires the use of no "vendor specific" primitives. Though the optical network protocol uses class 3, each RTL_Port is capable of receiving and transmitting frames with delimiters for all classes (1 through 3). However, the RTL_Port does not support class 1 and 2 applications. It will reject class 1 and 2 frames with the appropriate delimiters as required in FC-PH.

AC.3.3.2 Basic Link Services

Basic Link Services are handled by the microprocessor in the local node. These services are all done using the asynchronous mode of the interface. The local node at the network interface and the point to point interface to the terminal supports all Basic Link Services as defined in FC-PH rev 4.3 except for the Remove Connection service which is only used for class 1 connections.

AC.3.3.3 Extended Link Services

Extended Link Services are handled by the microprocessor in the local node as well. Like the Basic Link Services, the Extended Link Servic-

es are done in the asynchronous mode. The node supports Link Service Reject (LS_RJT), Accept (ACC), N_Port login (PLOGI), F_Port login (FLOGI), logout (LOGO), Abort Exchange (ABTX), Read Connection Status (RCS), Read Exchange Status (RES), Read Sequence Status Block (RSS), Read Timeout Value (RTV), Read Link Status (RLS), and ECHO.

Ports within the node do not support Link Service Busy (LS_BSY), Request Initiative (RSI), Establish Streaming (ESTS), Estimate Credit (ESTC), Advise Credit (ADVC), Test (TEST), and Reinstate Recovery Qualifier (RRQ).

AC.3.3.4 Login/Logout

Each port within a node supports the explicit login and logout procedures defined in FC-PH rev 4.3. Login can be done at any time to reestablish parameters, and can be done with or without a preceding logout.

AC.3.3.5 Use of Credit

RTL_Port support the use of buffer to buffer credit as defined in FC-PH to manage flow control. N_Port tied to the node's point to point interface use both buffer to buffer credit and end to end credit

AC.3.3.6 Timers

Each port within a node provides the timers defined in FC-PH. E_D_TOV is used with a resolution of 1 ns.

AC.3.3.7 Sequence/Exchange Status

Each port within a node maintains both Sequence Status Blocks (SSB) and Exchange Status Blocks (ESB) in accordance with FC-PH. The only time where sequence initiative is passed to to get SSBs and ESBs from a neighbor port to support error management.

AC.3.4 Point To Point Interface

At the point to point interface to its local terminal the node should provide the following programmable buffer space:

240 bytes	16 buffers
512 bytes	8 buffers
1056 bytes	4 buffers
2112 bytes	2 buffers

At a minimum the N_Ports used for the point to point interface to the node must support ACK_1.

AC.4 Fabrics

While the Real Time Loop is normally expected to be a continuous ring of RTL ports connected by point to point links, it is possible to place an intervening fabric between two RTL ports. In this case, in order to meet the real time requirements of the network, it is necessary for the fabric to provide a dedicated, in order path with a fixed path delay. If the fabric also supports the other requirements for RTL such as the Fairness algorithm, it may also route frames from outside the ring onto the ring network or route frames from the net elsewhere.

Annex AD (Informative)

Priority and Preemption

Real-time systems require interconnect networks that provide guaranteed bandwidth, guaranteed in-order delivery, and guaranteed latency. To meet these requirements, an interconnect network that resolves access contention using priority and preemption is desired.

A priority value in the Fibre Channel frame header is defined (high 7 bits of the OX_ID field, see FC-PH-3 clause 18) and can be used by a Fabric to resolve contention between N_Ports requesting a Dedicated Connection to a single resource N_Port. A 7 bit field is defined since this size enables efficient implementations of the Rate Monotonic Scheduling Algorithm.

Preemption in the context of a Fibre Channel Fabric is the act of establishing a connection to a resource or resources (if multicast is used) that is/are already a part of a dedicated connection. The act of preempting an existing dedicated connection is completed ensuring that complete frames are transmitted and received with link integrity maintained.

A preemption is initiated when a preemption request frame (**SOFc1** with preemption flag set = 1, defined in FC-PH-3 clause 18) is forwarded to the Fabric by an unconnected N_Port. The preemption request will result in (1) the preemption of an existing dedicated connection and the establishment of a new dedicated connection between the preemption requesting N_Port (the preemptor) and the desired destination(s) N_Port(s) (the preemption destination(s)), (2) the establishment of a dedicated connection between the preemptor the preemption destination(s), (3) or rejection of the preemption request by the Fabric. In a real-time application, rejection by the Fabric might be due to a priority value that is too low.

The process for performing a preemption is as follows:

Upon receipt of a request submitted by an FC-4 or other upper level protocol to initiate a con-

nection using preemption, the FC-2 protocol attempts to establish a connection using the **SOFc1**, with the preemption flag set = 1, preemption request frame. In the following figure, the preemptor P is sending a preemption request frame (**SOFc1** with preemption flag set = 1) to the Fabric.

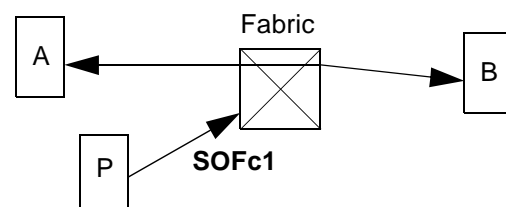

If the Fabric denies the request the Fabric returns a **F_RJT** Link_Response frame with a "preempt request rejected" reason code (FC-PH-3 clause 20) to the preemptor with no other effects on the Fabric. No connections are changed if the Fabric rejects a preemption request.

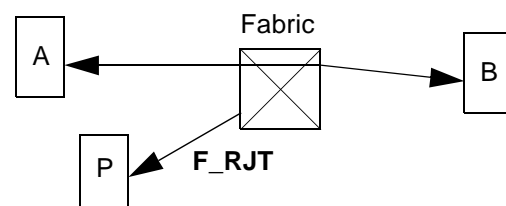

If the Fabric accepts the request, the Fabric terminates the connection(s) being preempted (A to B) by initiating the Link Reset protocol (FC-PH clause 16.6.5) to both the preempted connection initiator and recipient (A and B). Once the Link Reset protocol is complete the Fabric forwards an PRMT basic link service command (FC-PH-3 clause 21.2) to both the preempted connection initiator and recipient (A and B. N_

Ports A and B now know why they have abnormally terminated sequences that must be managed).

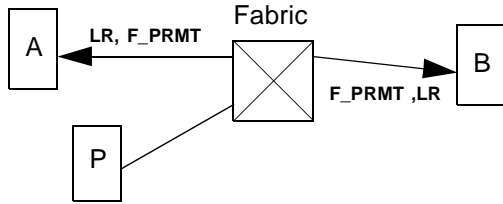

The Fabric then establishes a new connection (P to B) by forwarding the **SOFC1** preemption request frame to the preemption destination (B). The new dedicated preemption connection is established when the preemptor (P) receives the acknowledge from the preemption destination N_Port (B).

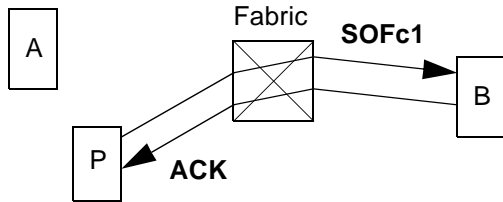

The sum of P_T_LR, R_T_LRR, and R_T_ID should be equal to n times the class 1 connection setup latency. Where the class 1 connection setup latency is the time from when the connection initiator forwarded the **SOFC1** to when the connection recipient detects reception of the **SOFC1**. The value of n is dependent on the application environment. High performance environments will want a small value of n (~1 or 2), other environments may be function with a value much larger.

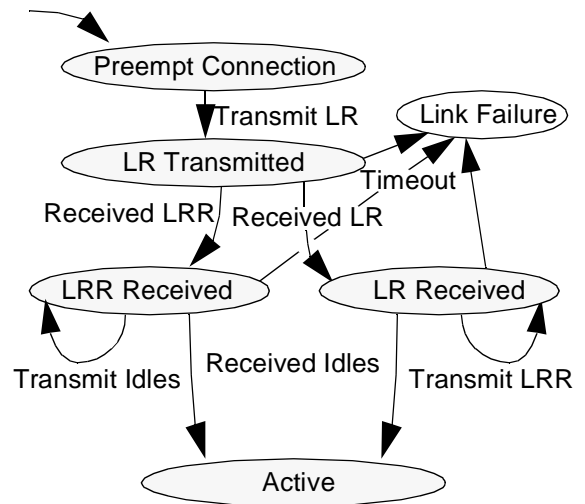

Link Reset Protocol: The link reset protocol, as defined in FC-PH clause 16.6.5 follows the process outlined in the preceding figure when used for preemption. The “Timeout” period is specified as the R_T_TOV value (FC-PH clause 29.2.1.1) for detection of loss of synchronization (see FC-PH clause 12.1.1.2). To guarantee timely progress through the preemption sequence the following delays should be specified by the application layer profile.

- P_T_LR, Preempt Connection state to Transmit LR
- R_T_LRR, Received LR to Transmit LRR
- R_T_ID, Received LRR to Transmit Idles

Reasonable values for these event delays are dependent on the application that is using preemption. A rule of thumb that could be useful might be:

Annex AE (Informative)

Report Node Capabilities (RNC)

AE.1 Background

Much information about an N_Port can be determined from its login parameters and how it responds to certain requests. For example the login parameters may indicate that Class 1 and Class 3 are not supported. A failed process login attempt may indicate an N_Port does not support FCP. A time-out waiting for a response may indicate an N_Port does not support FC-LE (IP). Although ways exist to obtain much of the information desired, some items can not be determined without the use of vendor specific fields. For example, an N_Port which can operate under both the Class 2 only and mixed-mode (Class 1 and 2) variations of the FCSI profiles does not have a standard method to indicate which is preferred (and likely to give the best performance).

The RNC link service was designed to meet the following goals:

- Provide a standard way to discover what protocols and standards an N_Port supports (its capabilities).
- Provide a method to select a specific capability from a list of supported capabilities.
- Provide a method to indicate preference or relative level of support of a specific capability (e.g. support of a profile) when multiple capabilities are supported for a given protocol.
- Provide a method to exchange and set new and additional parameters not specified during N_Port login.
- Provide a standard method to select vendor unique operation modes or profiles.

AE.2 Operation Modes

The RNC link service may be used in two distinct modes:

- Querying the capabilities of an N_Port

- Setting specific operating modes or parameters

AE.2.1 Query Function

Using the RNC link service to query the N_Port's capabilities may be accomplished by setting the RNC_Flags 'Select' bit to 0. The requesting N_Port may, but is not required to, supply Capability Entries in the RNC payload. The Vendor Identifier must always be supplied. The requesting N_Port must keep the length of the RNC payload less than or equal to 256 bytes. This requirement relieves the responding N_Port from dealing with an arbitrarily large, unsolicited link service.

The responding N_Port, upon receiving an RNC request with the Select bit 0, should respond with an RNC Accept payload which lists all of the node's capabilities it wishes to report. No length restriction exists on the RNC Accept because it is solicited. Also, there is a desire to keep the responder's requirements at a minimum. The responder may choose to vary the capabilities reported based upon the Vendor Identifier in the RNC request.

AE.2.2 Selection Function

The RNC link service is designed to allow either the requesting or the responding N_Port to actually make the selection from the list of supported capabilities.

If the requesting N_Port wishes to allow the responding N_Port to make the selection, it sends an RNC request with a list of the capabilities it supports and the Select bit set to 1. The responding N_Port will choose one capability from the list and include it in the response.

The requesting N_Port can make the selection itself by first issuing an RNC with the Select bit set to 0 (query). It then evaluates the list of capabilities in the RNC Accept and selects one. Finally, it issues an RNC request with the Select bit set and the selected Capability Entry. The responding N_Port will then be forced to select the desired entry.

Of course there may be variations on the above. A requesting N_Port may only support a small set of capabilities (possibly only one). It may choose not to query the capabilities of the other node first, but issue an RNC with Select set to 1 immediately.

Multiple Selections: There may be cases when both N_Ports support two distinct protocols or classes of capabilities. For example two N_Ports may communicate using both FCP and FC-LE (IP) protocols. In this case the requesting N_Port should only list the FCP related capabilities in one RNC request. After the FCP profile selection is made, the N_Port would then issue a second RNC request with the Select bit set and list profiles or capabilities associated with the FC-LE (IP) protocol.

The RNC definition does not attempt to define which documents support what protocols or in any way group associated documents. It is assumed the N_Ports implementing the protocols and various capabilities will handle the required associations and distinctions.

Preference Bits: The Preference bits may be used to aid the selection choice in the event there are multiple capabilities listed. The two bits provide a range of four values to rank the relative preference of multiple capabilities. For example an N_Port may support three profile variations for FCP; FCSI SCSI with Class 2, FCSI SCSI mixed mode, and a vendor unique FCP profile. The node may wish to assign a preference as follows:

- 00 (Best) - Vendor unique FCP
- 01 - FCSI SCSI mixed mode (protocol chip may be designed for Class 1)
- 11 (Worst) - FCSI SCSI w/Class 2 (supported for interoperability reasons, but poor performance)

Of course another N_Port may work best with FCSI SCSI with Class 2. The idea is that an N_Port may have hardware or software implementations which favor a certain operating mode. The Preference bits allow that information (in a limited way) to be exchanged with other N_Ports.

Invalidate Bit: The Invalidate bit allows a change in a previous selection. Unless the Invalidate bit is set, additional RNC requests with

the Select bit set to 1 are assumed to be selecting additional capabilities which are unrelated (non-conflicting) with previously chosen capabilities.

To “renegotiate” a capability, the specific capability selected in the prior RNC request should be included in the new RNC request as the first Capability Entry with the Invalidate bit set to 1. The capabilities the requesting N_Port wishes the replacement selection to be made from should follow the entry marked invalid.

Extensions: Extensions to a Capability Entry allow option bits, parameters, or other information to be specified as a capability. The document referenced in the Capability Entry is responsible for defining the meaning of all fields in the extension except the Extension Length.

An example usage of extensions would be if a document defined a new feature which would allow increased performance. The use of the feature, however, may break older devices which do not have the feature. An extension bit or field in the RNC capability entry for that document could be used to indicate support.

The length of any extensions must be a multiple of four bytes (including the extension length field). This ensures that all capability entries start on a 32 bit word boundary.

Vendor Unique Indication: Two bits of flags are used to indicate vendor unique options. If the Capability Entry is marked as vendor unique then the value assigned for the document identifier is determined by the vendor. No attempt is made to coordinate vendor unique document identifier values across vendors. Thus, interpretation of a vendor unique document identifier must be in conjunction with the 8 byte ASCII Vendor Identifier in the RNC or RNC Accept payload.

A value of ‘00’ indicates the referenced document is not vendor unique.

A value of ‘01’ indicates the referenced document is vendor unique. The vendor which defined the vendor unique document is the one listed in the Vendor Identifier field of the current RNC or RNC Accept payload.

A value of ‘10’ indicates the referenced document is vendor unique, but it is defined by the other N_Port. For example, if vendor ‘A’ supports a unique profile ‘y’, then vendor ‘A’s N_

dpANS X3.xxx-199x

Port would use a Vendor Unique flag value of '01' in the capability entry for profile 'y' when it sends an RNC request. If the request goes to an N_Port made by vendor 'B', and the receiving N_Port is aware of and supports the profile defined by vendor 'A', then vendor 'B's N_Port would indicate support for vendor 'A's profile by using a Vendor Unique flag value of '10' for the capability entry for profile 'y', in the accept payload.

Index

A

ACC (Accept) 34
Address identifiers 22
Association_Header 29

C

Clock synchronization 73

D

Definitions 2

E

E_D_TOV 34
 Resolution 31, 34, 43, 47, 49, 54, 66
Editorial conventions 2
Exchange management 58
Exchange Status Block 58
Extended Link Service commands
 Read Timeout Value (RTV) 32, 34
 Report Vendor Unique Information
 (RVU) 2, 33, 35–39

F

F_CTL
 Abort Sequence Condition 22
Fabric Login 88
FC-4 Region 2, 3–4

K

Key Distribution Server 22

L

Logout 89
Long video cable 17

M

Miniature coax cable 18
Multicast 29

N

N 89
N_Port Login 89

O

Optional headers
 Association_Header 29

OX_ID 26

P

Priority 22, 27–??, 43, 52, 53–??, 55
Process Policy 25, 66
Process_Associator 29
Profile 2, 36

R

R_A_TOV 34
Read Timeout Value (RTV) 32, 34
Report Vendor Unique Information (RVU) 2,
 33, 35–39
Request Clock Synchronization (REQCS) 2,
 78

S

Sequence 59
Sequence Status Block 59
Shielded twisted pair cable 18

T

Time Server 56
TV 17
TYPE 22, 82

V

Video cable 17

*End of
Document*